

A38E

ELECTRIC ARTICULATED BOOM LIFT



- Popular electric articulated boom lift
- Lightweight, durable and reliable
- Smooth, easy to use controls
- Compact chassis for excellent manoeuvrability
- Suitable for indoor and outdoor use



snorkel[™]

www.snorkellifts.com

ELECTRIC ARTICULATED BOOM LIFT

A38E

DIMENSIONS	A38E
Max. working height	13.5m
Max. platform height (A)	11.5m
Max. working outreach	6.1m
Clearance height at max. outreach	5.4m
Platform size (E x F)	0.69m x 1.11m
Overall width (B)	1.5m
Overall length (C)	4.1m
Stowed height (D)	2.0m
Ground clearance	120mm

PERFORMANCE	
Platform capacity (SWL)	215kg
Max. drive height	11.5m
Max. wind speed	12.5m/s
Max. drive speed (stowed)	4.0km/h
Max. drive speed (elevated)	0.65km/h
Platform rotation	90° (+45°/-45°)
Turret rotation (non-continuous)	360°
Tailswing (riser boom elevated)	0m
Tailswing (riser boom stowed)	1.4m
Raise/lower time	83/68 sec
Gradeability	36%
Inside turning radius	1.12m
Outside turning radius	2.4m
Tyres	22 x 9 16 non-marking rubber
Controls	proportional
Drive system	direct drive DC

POWER	
Power source	8 x 6V, 220Ah batteries
Battery charger	100-200V/15A

WEIGHT	
Weight	3,880kg

WORKING ENVELOPE

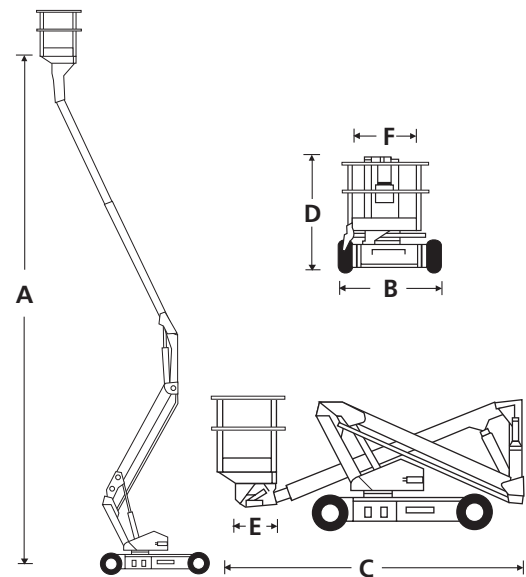
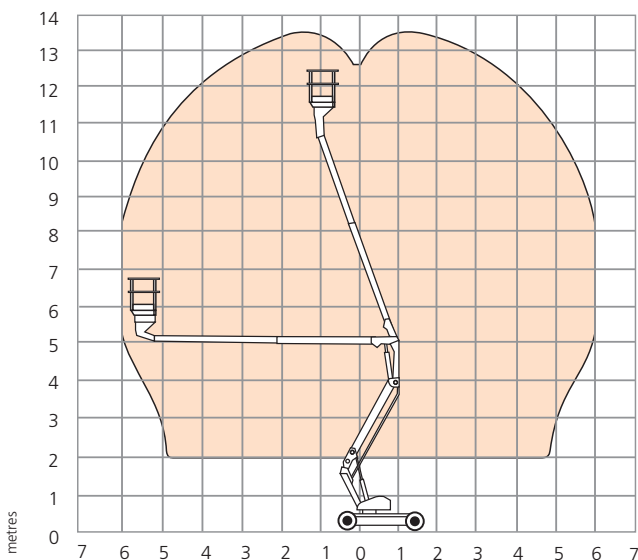

STANDARD FEATURES

- Snorkel Guard™ secondary guarding system
- Proportional one-handed controls
- Hydraulic platform rotation
- Minimal front boom overhang
- Ultra-tight inside turning radius
- Power line to platform
- Tilt alarm and cut-out
- 2 person indoor
- 1 person outdoor
- Direct DC drive series wired wheel motors
- Non-marking tyres
- Duplicate boom controls at ground level
- Hour meter & on-board diagnostics display
- Flashing amber light
- 2 year parts & labour, 5 year structural warranty
- CE approved

OPTIONS

- Special paint colours
- Environmental hydraulic oil
- Snorkel OnSite™ telematics



☎ **1300 BROOKS** (1300 276 657)
 @ sales@brooksaccess.com.au
 🌐 www.brooksaccess.com.au