

BROOKS HIRE

"Better Being With Brooks"

6x6 Cab Chassis
AD380T45W



FOR MINING & CONSTRUCTION



WATER TRUCK

AES 18000

Product Specifications

TANK CAPACITY
18,000L

DRIBBLE BAR
125mm

HOSE REEL
15m x 25mm

Iveco 6x6 Cab Chassis

AES 18000 Water Truck Module c/w fully independent ROPS system designed and fabricated to ISO 3471 /3449 standards to suit cab over chassis.

STANDARD EQUIPMENT

TANK CAPACITIES

- 18,000 litres with Top drainage system and splash guards to prevent water run off over front of tank.

TANK FITTINGS

- Top fill point funnel, drivers' side, site level gauges front and rear.
- Handrails around the top of the tank Fold down design for transport purposes.

HYDRAULICS

- Supply & installation of a Hotshift PTO (subject to configuration) to suit a high lift water Pump.
- A Spin on type return line filter.
- A 200-litre oil tank will be integrated into the front left corner of the water tank.

PUMP SYSTEM

- 80mm NB high lift water pump.
- Pressure outlets include a 25mm ball valve outlet for hose reel and 2" bsp ball valve.

CAB CONTROLS

- Air switched controls will be fitted into a control box mounted in the centre console or positioned in the most convenient location within the cab for easy access by the operator.

LIGHTING

- Two (2) LED and two (2) work lights located at top corners of tank.
- Reverse alarm and reverse light fitted.
- Beacon fitted on ROPS & Rear of tank.

REVERSING CAMERA

- Camera is fitted to the rear of the tank connected to radio unit display.

BUMPER

- Full width bumper incorporating LED taillights & clearance lights.

CANNON

- Air operated, mounted in rear right-hand corner remote controlled from cabin.

HOSE REEL

- Manual Rewind complete with 15m x 25mm hose and variable spray water faucet.

FAN SPRAYS

- Three (3) magnum air operated spray heads. One left, one right and one central. All individually controlled from cabin.

DRIBBLE BAR

- 125mm full width gravity fed type with air operated butterfly valve controlled from cabin.

OTHER PIPING

- Fill point fitted with a camlock, and cap c/w manual butterfly valve Pipe set up with creek suction for self-filling.

FIRE EXTINGUISHERS

- 9kg dry powder fitted to driver's side ROPS and Rear platform.

TANK PAINTING

- Tank and all components sandblasted to class 2½. Internal tank lining will be two pack epoxy to minimum 200 micron.

EMERGENCY STOPS

- Fitted 1 x inside and 1 x Drivers side external.

SAFETY EQUIPMENT

- 1 set of Wheel Chocks and 1 set of Reflective Triangles, 1 basic first aid kit.

OTHER

- Supply and fit additional fire extinguisher at rear of truck
- Extend hydraulic tank breather
- Nut tags to be fitted to all wheel nuts
- Whip aerial to 4.2m
- On highway fill level
- Starter & battery isolator
- 24 V Jump Start receptacle
- DG3 Hi Vis tape fitted to tank
- Chassis rust proofing



1300 BROOKS (276 657)

@ sales@brookshire.com.au

www.brookshire.com.au



6x6 Cab Chassis
AD380T45W

ENGINE

Power: 450hp (331kW) @ 1900rpm
Torque: 2200Nm @ 1000rpm

TRANSMISSION

16 Speed Automated Manual

MASS RATINGS

GVM: 32000kg
GCM: 60000kg

WHEELBASE

4500mm (Standard)
3800mm, 4200mm (Optional)

KEY FEATURES

- Electronic Braking System with Off-road mode
- Transmission interarder and Engine brake
- Compliant to Euro VI Step E Emission standard
- Full LED Headlights with cornering fog lights
- 7" Infotainment system with Apple CarPlay & Android Auto
- Climate control HVAC system
- IVECO Telematics

*For available options & details see the next pages.

WARRANTY*

Standard Warranty

2 Years/500,000km/6,000 hours (whichever occurs first)

Extended Warranty

Optional - up to 5 Years/500,000km/6,000 hours (whichever occurs first)

	Driveline Only	Driveline & other components
Driveline	•	
Extra Driveline	•	•

MAINTENANCE & REPAIR CONTRACT*

	Maintenance	Friction	Repair
Service Bond	•		
Friction	•	•	
Easy Road	•	•	•

Contracts available up to 5 Years/500,000km/6,000 hours (whichever occurs first)

*Please refer to the 'Standard Inclusions List' at your IVECO Dealer.



📞 1300 BROOKS (276 657)
@ sales@brookshire.com.au
🌐 www.brookshire.com.au

ENGINE

Engine Model	Cursor 13
Total Displacement	12,900cm ³
Maximum Power	450hp (331kW) @ 1900rpm
Maximum Torque	2200Nm @ 1000rpm

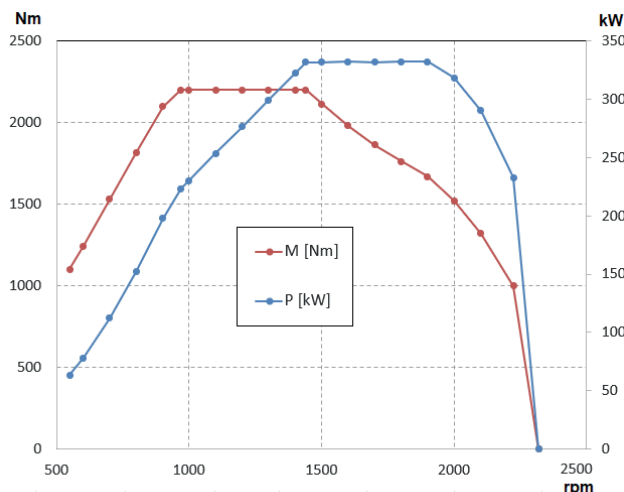

Injection type	Direct
Fuel Injection system	Common rail
Bore & Stroke	135 & 150mm
After-Treatment System	Hi-e SCR after-treatment system with DOC: Diesel Oxydation Catalyst DPF: Diesel Particulate Filter SCR: Selective Catalytic Reduction CUC: Clean Up Catalyst
Emission Compliance	Euro VI STEP E

TRANSMISSION

Description	Automated Manual Transmission	
Make & Model	Hi-Tronix 16TX 2240 TO	
Clutch	Single dry plate, Outer diameter: 430 mm	
Shifter type	Dash mounted electronic shifter with column mounted sequential shifter	
Gear ratios: Hi-Tronix 16TX 2240 TO	1st: 14.68	9th: 3.22
	2nd: 12.05	10th: 2.64
	3rd: 9.92	11th: 2.17
	4th: 8.14	12th: 1.78
	5th: 6.78	13th: 1.49
	6th: 5.56	14th: 1.22
	7th: 4.57	15th: 1.00
	8th: 3.75	16th: 0.82
	Rev 1: 14.14	Rev 3: 3.10
	Rev 2: 11.61	Rev 2: 2.54

TRANSFER

Model Name	TC 2200
Number of speeds	2
OFF ROAD/Low Ratio	1.6
ON ROAD/Normal Ratio	1.0

DRIVE AXLE(S) RATIO

Drive axle(s) ratio	4.23
---------------------	------

PERFORMANCE

Turning circle (Kerb to kerb)	22300mm
Engine RPM @ 100km/h	1763
Road speed limiter	100km/h, Conforms to ADR65
Gradeability ¹ @ Rated GVM	100% (with 1:6 Transfer ratio)
Gradeability ¹ @ Rated GCM	64% (with 1:6 Transfer ratio)

¹This is theoretically calculated. Actual performance may vary under different conditions.

AXLE & SUSPENSION

Front Axle Model & Type	IVECO 5985/2D Drive axle - Hub reduction
Front suspension	Parabolic suspension with dampers
FA & suspension capacity	8000kg
Front Stabiliser bar	Equipped, Diameter: 40mm
Rear Axle Model & Type	IVECO 453291/2D - Tandem - Hub reduction
Rear suspension	4 Leaf parabolic suspension
RA & suspension capacity	26000kg
Rear Stabiliser bar	Equipped, Diameter: 50mm
Diff Locks on drive axles	Equipped
Road friendly suspension	N/A

BRAKES & AUXILIARY BRAKES

Type/Control	Full air/Electronic Braking System (EBS) - Off road mode - ABS (Anti-lock Braking System) - ASR (Anti-Skid Regulator) - DPI (Direct Brake Integration) - BAS (Brake Assistant System) - BVR (Brake Lining Wear Adjustment) - ARB (Hill Holder) - only with AMT gearbox
Front axle	Drum 410mm/Friction area: 2884cm ²
Rear axle	Drum 410mm/Friction area: 3220cm ²
Engine brake	Equipped
Transmission Intarder	Equipped

CHASSIS

Dimensions	309x80x10mm
Chassis width (at rear)	776mm
Material	Steel
Tensile strength	610 N/mm ²
ATS Location	LHS Chassis
Type/Control	Standard: Vertical Optional: Horizontal
Front tow hook	Equipped
Towing cross member	Equipped (D=200kN)

WHEELS & TYRES

Rim Type	10-Stud Steel wheel (ISO type) PCD 335mm
Rim size	Front 11.75" x 22.5" Rear 9.0" x 22.5"
Tyre size	Front 385/65/R22.5 Rear 315/80/R22.5



1300 BROOKS (276 657)
@ sales@brookshire.com.au
www.brookshire.com.au

FUEL & ADBLUE® TANK

Fuel Tank with lockable cap	550L
AdBlue® Tank	60L

SAFETY FEATURES

Lane Departure Warning System (LDWS)	Optional
Tyre pressure monitoring system (TPMS)	Optional
Reverse Buzzer	Equipped
Daytime Running Lamp (DRL)	Equipped
ECE-R29.03 Cab Strength Certification	Equipped

ELECTRICAL & ELECTRONICS

Voltage	24V System
Batteries	2x 12 Volt/170Ah Batteries
Electrical battery cutout	Equipped
Battery position	Horizontal on side frame -LHS
Alternator	28 Volt/90A
Fleet Management System interface (FMS)	Equipped
Chassis mounted jump start plug	Equipped
CAN OPEN Bodybuilder interface	Equipped
LED Headlamp - Low beam	Equipped
LED Headlamp - High beam	Equipped
Daytime Running Lamp (DRL)	Equipped
Fog light with cornering & bending	Equipped
LED Rear lights	Equipped
Provision for roof rotating lights	Equipped with harness & switch Optional: 2 x roof rotating lights
Chassis mounted pneumatic horn	Equipped
7-pin trailer connection	Equipped
USB charging port (TYPE A)	Equipped
12 Volt power socket	Equipped

STEERING

Adjustable steering column	Equipped
Steering wheel	Leather steering wheel with following: - Controls for the information screen - Controls for the phone - Activation for voice recognition - Controls for radio/media volume

CAB EXTERIOR

Cab type	Day cab with low roof - 2300mm wide
Cab tilt mechanism	Servo assisted cab tilt mechanism
Cab mounting	Mechanical spring suspended front and rear
Windscreen Wipers	Automatic - Rain sensing 2 Speed with Integrated Washer Nozzles
Front Bumper	Steel front bumper with foldable step
Headlight protection grid	Equipped
Rearview mirrors	2 x Motorised, heated main mirrors & spotters 1 x LHS kerb view & front view mirrors
External Sunvisor	Equipped
Colour	White IC 194

CAB INTERIOR

Seating capacity	Two Optional: Three
Driver Seat	Fabric, Air suspended, Heated, 3-Way adjustable seat Optional: Fabric, Air suspended, Ventilated, 3-Way adjustable seat
Passenger Seat	Fabric, Air suspended, Heated, 3-Way adjustable seat
Seat Belt	3-point Lap/Sash type 7" LCD HD touch screen display DAB + AM/FM radio, USB input, Bluetooth®connectivity Smart phone mirroring
Multimedia unit	- Apple CarPlay® - Android Auto® Voice recognition In built Tom Tom Satellite navigation system Reverse/Side camera compatible
HVAC System	Equipped - with climate control
Immobiliser	Equipped - with 3 x remote central lock keys
Power Windows	Equipped
Roof hatch	Equipped
Cup holders	Equipped
Interior lighting	Equipped
Rollup sun blinds	Equipped - for the doors

IVECO TELEMATICS

Smart connectivity pack	Equipped Features include: - MYIVECO Smart report - MYIVECO Web portal - MYIVECO Vehicle monitoring & remote assistance - MYIVECO Easy Way app
Premium pack	Upon subscription

*Conditions apply. For further information please visit iveco.com.au



1300 BROOKS (276 657)

@ sales@brookshire.com.au

www.brookshire.com.au

MODEL CODE: AD380T45W

Application Rigid

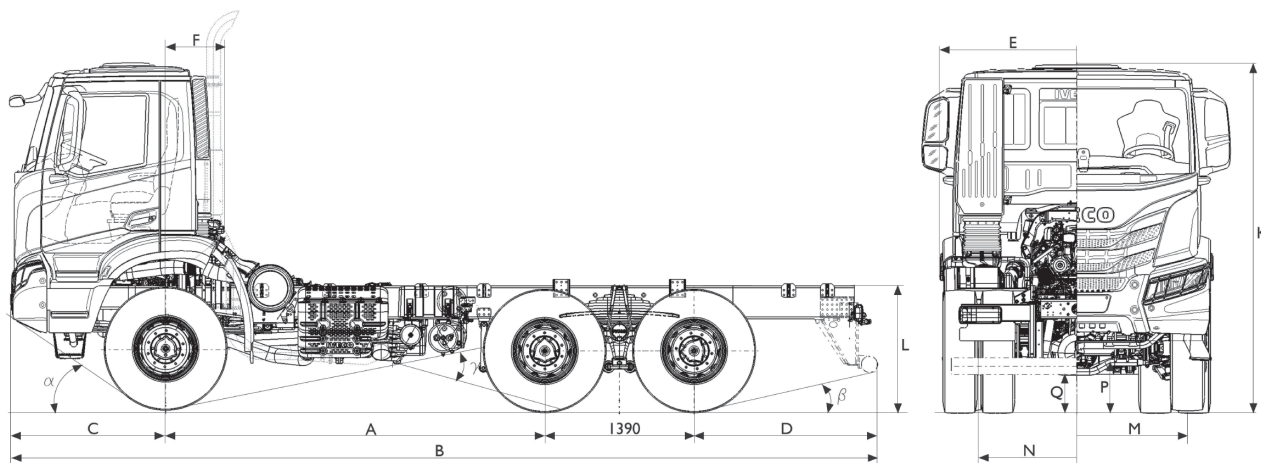

DIMENSIONS & WEIGHTS

Wheelbase (A)	4500mm	4200mm	3800mm
Overall length (B)	9597mm	9327mm	8697mm
Max width over fenders (E)	2500mm		
Front axle to back of cab (F)	580mm		
Frame height at end of frame, unladen (L)	1169mm	1169mm	1169mm
Front overhang (C)	1440mm		
Rear overhang (D)	2075mm	2075mm	1850mm
Minimum ground clearance (front) (P)	346mm		
Minimum ground clearance (rear) (Q)	286mm		
Overall height to top of cab, unladen (K)	3213mm	3213mm	3213mm
Turning diameter kerb to kerb	22300mm	21500mm	20300mm
Turning diameter wall to wall	23900mm	23100mm	21900mm
Front track (M)	1981mm		
Rear track (N)	1827mm		
Approach angle α (°)	33°	33°	33°
Departure angle β (°) with OPT:194	8°	8°	8°
Ramp angle γ (°)	19°	19°	20°
Total vehicle kerb weight*	10257kg	10210kg	10154kg
Kerbweight on Front Axle*	5589kg	5550kg	5509kg
Kerbweight on Rear Axle*	4668kg	4660kg	4654kg
Gross Vehicle Mass (Plated)	33500kg		
Gross Combination Mass (Plated)	60000kg		

*Indicative chassis tare mass with Standard options, without fuel, AdBlue and driver. ±3% tolerancy applies.

IVECO TRUCKS AUSTRALIA LIMITED ABN 86 004 065 061 LEVEL 10, 14 MASON STREET, DANDENONG, VICTORIA 3175 PO BOX 117 DANDENONG, VICTORIA 3175 TELEPHONE (03) 9238 2200 WWW.IVECO.COM.AU
 THE INFORMATION IN THIS DOCUMENT WAS CORRECT AT THE TIME OF PRINTING. THE DATA IN THIS DOCUMENT IS APPROXIMATE. IF AN EXACT WEIGHT OR DIMENSION IS REQUIRED PLEASE CONTACT YOUR LOCAL
 AUTHORISED IVECO DEALER. ALWAYS CONSULT AN AUTHORISED IVECO DEALER FOR THE LATEST INFORMATION ON THE VEHICLE BEFORE DECIDING TO PLACE AN ORDER. OVERSEAS IMAGES ARE SHOWN THROUGHOUT
 THIS DOCUMENT AND IMAGES MAY REFER TO EQUIPMENT THAT IS OPTIONAL. THE MODELS DESCRIBED CAN BE SUBJECT TO MODIFICATIONS WITHOUT ANY NOTICE BY THE MANUFACTURER. IVE3128-6X6CC-SS. 10/2023.



☎ 1300 BROOKS (276 657)
 @ sales@brookshire.com.au
 🌐 www.brookshire.com.au