

1 8 5 - 2 3 0 S A E N E T H O R S E P O W E R



D

MOTOR GRADER

772D



SIX-WHEEL DRIVE

Specifications

Engine 772D

Type	John Deere PowerTech™ 6081H; meets EPA Tier II non-road emissions regulations	
Rated Speed	2,100 rpm	
Engine Power		
Gears 1–2 (6WD on)	198 gross hp (148 kW) / 185 net hp (138 kW)	
Gears 3–5 (6WD on)	227 gross hp (169 kW) / 215 net hp (160 kW)	
Gears 6–7 (6WD on)	246 gross hp (184 kW) / 230 net hp (172 kW)	
Gear 8 (6WD off)	232 gross hp (173 kW) / 215 net hp (160 kW)	
Aspiration	turbocharged with waste-gate boost pressure regulation and air-to-air aftercooler	
Number of Cylinders	6	
Displacement	494 cu. in. (8.1 L)	
Fuel Consumption, Typical (depending on duty cycle)	4.0 to 10.3 gal./hr. (15.1 to 39.0 L/h)	
Net Torque @ 1,000 rpm	<i>6WD off</i>	<i>6WD on</i>
Gears 1–2	738 lb.-ft. (1001 Nm) @ 65% net torque rise	778 lb.-ft. (1055 Nm) @ 59% net torque rise
Gear 3	778 lb.-ft. (1055 Nm) @ 59% net torque rise	838 lb.-ft. (1136 Nm) @ 52% net torque rise
Gears 4–5	822 lb.-ft. (1114 Nm) @ 53% net torque rise	838 lb.-ft. (1136 Nm) @ 52% net torque rise
Gears 6–7	929 lb.-ft. (1260 Nm) @ 58% net torque rise	950 lb.-ft. (1288 Nm) @ 55% net torque rise
Gear 8	929 lb.-ft. (1260 Nm) @ 58% net torque rise	N/A
Lubrication	pressure system with full-flow filter and cooler	
Air Cleaner with Restriction Indicator	dual element, dry, with tangential unloader	
Electrical System	24 volt with 100-amp alternator	
Batteries (two 12 volt)	1,400 cold-cranking amps, 440-min. reserve capacity	

Steering and Articulation

All-hydraulic power frame articulation for maneuverability and productivity; crab steering reduces side drift, positions tandems on firm ground, and increases side slope stability	
Front steer plus articulated	
Articulation (both left and right)	22 degrees
Turning Radius (front steer plus articulation)	23 ft. 6 in. (7163 m)
Front Wheel Lean	20 degrees

Six-Wheel Drive

Automatic dual path; increases tractive effort and front-end control; includes separate left and right systems with variable-displacement pumps, axial piston wheel motors, free wheel at transport speeds, operator-selectable 15-position rotary aggressiveness control, inching capability down to 0 mph, and on/off control	
Effective in Gears 1–7 Forward and Reverse	
Hydrostatic Pumps (2)	3.9 cu. in. (64 cm ³) each
Wheel Motors, Variable Displacement	1.2 to 3.7 cu. in. (20 to 60 cm ³)
Final Reduction	38.7:1

Tires and Rims

Tire Size	Front	Rear
14.00-24 on 10-in. (254 mm) Rim		
Wheel Tread (on ground)	82 in. (2.08 m)	82 in. (2.08 m)
Overall Width (top of tires)	99 in. (2.51 m)	98 in. (2.49 m)
Ground Clearance (front axle)	23.1 in. (587 mm)	
17.5-25 on 14-in. (356 mm) Rim		
Wheel Tread (on ground)	85 in. (2.16 m)	85 in. (2.16 m)
Overall Width (top of tires)	104 in. (2.64 m)	104 in. (2.64 m)
Ground Clearance (front axle)	23.1 in. (587 mm)	

Productivity

Blade Pull @ Maximum Weight and 0.9 Coefficient of Traction	43,200 lb. (19 595 kg)
---	------------------------

Operating Weights

SAE Operating Weights With Standard Equipment	
Front	9,620 lb. (4364 kg)
Rear	24,660 lb. (11 186 kg)
Total	34,280 lb. (15 549 kg)

Operating Weights (continued) 772D

Typical Operating Weights with Front Push Block and Ripper	
Front	11,160 lb. (5062 kg)
Rear	29,630 lb. (13 440 kg)
Total	40,790 lb. (22 630 kg)
Maximum Operating Weight (snow equipment)	
Rear	32,160 lb. (14 587 kg)
Total	48,000 lb. (21 772 kg)

Transmission

Type	direct-drive John Deere PowerShift Plus™, modulated shift on-the-go, five working speeds below 9 mph (15 km/h), inching pedal @ 2,000 rpm with 14.00-24 tires
Travel Speeds (with no tire slip)	
Shift Lever Position 1	2.2 mph (3.5 km/h)
Shift Lever Position 2	3.1 mph (5.0 km/h)
Shift Lever Position 3	4.4 mph (7.1 km/h)
Shift Lever Position 4	6.2 mph (10.0 km/h)
Shift Lever Position 5	9.3 mph (15.0 km/h)
Shift Lever Position 6	13.1 mph (21.1 km/h)
Shift Lever Position 7	18.3 mph (29.5 km/h)
Shift Lever Position 8	25.8 mph (41.5 km/h)

Final Drives

Spiral bevel differential, inboard-mounted planetary sealed in cooled, filtered oil; operator-controlled differential lock/unlock; 2-in. (51 mm) pitch tandem drive chains

Front Axle

Heavy-duty, welded box construction	
Oscillation (total)	32 degrees
Wheel Lean (each direction)	20 degrees

Brakes

Foot-controlled, hydraulically operated, multiple wet-disc brakes sealed in cooled, filtered oil; self adjusting, maintenance free; includes spring-applied, hydraulically released parking brake; both independent braking systems effective on all four tandem wheels

Hydraulic System

Type	closed center, pressure compensated load sensing (PCLS), variable-displacement piston pump, O-ring face seal fittings
Hydraulic Pump	5.5 cu. in. (90 cm ³)
Rated Flow @ 2,000 rpm	54.7 gpm (207 L/min.)
Maximum System Pressure	2,750 psi

Blade Function

All-hydraulic, industry preferred hand-lever placement of blade-function controls; includes float position; easy conversion from two-hand to one-hand blade-lift control; seven blade-lift arm positions	
Blade Range	
Lift Above Ground	18.5 in. (470 mm)
Blade Side Shift, Right or Left	26.9 in. (680 mm)
Shoulder Reach Outside Wheels (Frame Straight)	
Right	82 in. (2083 mm)
Left	82.5 in. (2096 mm)
Pitch at Ground Line	42 degrees forward / 5 degrees back

ROPS

Low-profile cab, full-height cab, and canopy ROPS (Rollover Protective Structure) meet criteria within SAE J1040MAY 1994, ISO 3471-1997, SAE J397MAY1994, and ISO 3164

Mainframe

Type	welded box construction
Width, Minimum	12.07 in. (306.5 mm)
Height, Minimum	10.63 in. (270 mm)
Thickness	
Sides	0.63 in. (16 mm)
Top and Bottom	1 in. (25 mm)
Weight per ft., Minimum	116.5 lb./ft. (173.7 kg/m)
Minimum Vertical Section Modulus	113.5 cu. in. (1860 cm ³)
Average Vertical Section Modulus at Saddle	157 cu. in. (2572 cm ³)

Draft Frame

Welded box construction machined for flatness with double ball-and-socket pivot connection, equipped with replaceable wear inserts

Circle 772D

Type	welded construction, heat treated for strength, machined for flatness, equipped with replaceable wear inserts
Circle Diameter	60 in. (1520 mm)
Rotation	360 degrees
Drive	hydraulic motor and worm gear with positive lock
Side Shift	
Right	28.5 in. (724 mm)
Left	31 in. (787 mm)

Moldboard

Type	high-strength, pre-stressed, wear-resistant, high-carbon steel, equipped with replaceable side-shift wear inserts
Length	12 ft. 0 in. (3.66 m)
Height	24 in. (610 mm)
Thickness	0.88 in. (22 mm)

Cutting Edge

Type	Dura-Max® through-hardened steel edge
Thickness and Width	0.62 x 6 in. (16 x 152 mm)

Front Scarifier

Type	V-type manual two-pitch position with hydraulic float
Width of Cut	48 in. (1219 mm)
Number of Teeth	5 standard, can hold up to 9
Lift Above Ground	21.8 in. (554 mm)
Maximum Penetration	13.3 in. (338 mm)
Shank Size	1 x 3 in. (25 x 76 mm)

Rear Ripper / Scarifier

Type	parallelogram linkage with manual valve control and hydraulic float, tool bar for five ripper and nine scarifier shanks
Ripper	
Width of Cut	87 in. (2210 mm)
Number of Shanks	3 standard, can hold up to 5
Lift Above Ground	21.4 in. (544 mm)
Maximum Penetration	18 in. (457 mm)
Shank Size	2.25 x 5.5 in. (57 x 140 mm)
Scarifier	
Width of Cut	87 in. (2210 mm)
Number of Teeth	can hold up to 9
Lift Above Ground	26.8 in. (681 mm)
Maximum Penetration	12.7 in. (323 mm)
Shank Size	1 x 3 in. (25 x 76 mm)

Capacities (U.S.)

Fuel Tank	106 gal. (401.2 L)	Differential Housing	9.5 gal. (36 L)
Cooling System	13 gal. (49.2 L)	Tandem Housings (each)	20 gal. (75.7 L)
Engine Lubrication, Including Filter	7.5 gal. (28.4 L)	Circle Gearbox	1.5 gal. (5.7 L)
Transmission	6 gal. (22.7 L)	Hydraulic Reservoir	14 gal. (53 L)

Dimensions

A Height to Top of Cab*	10 ft. 5 in. (3175 mm)	F Wheelbase	20 ft. 1 in. (6120 mm)
B Height to Top of Exhaust	122 in. (3099 mm)	G Overall Length	28 ft. 10 in. (8800 mm)
C Height to Top of Blade-Lift Cylinders	116 in. (2946 mm)	H Overall Length with Scarifier	373 in. (9474 mm)
D Tandem Axle Spacing	60.8 in. (1544 mm)	I Overall Length with Scarifier and Ripper	408 in. (10 363 mm)
E Blade Base	8 ft. 9 in. (2670 mm)		*Add 8.9 in. (225 mm) for full-height cab.

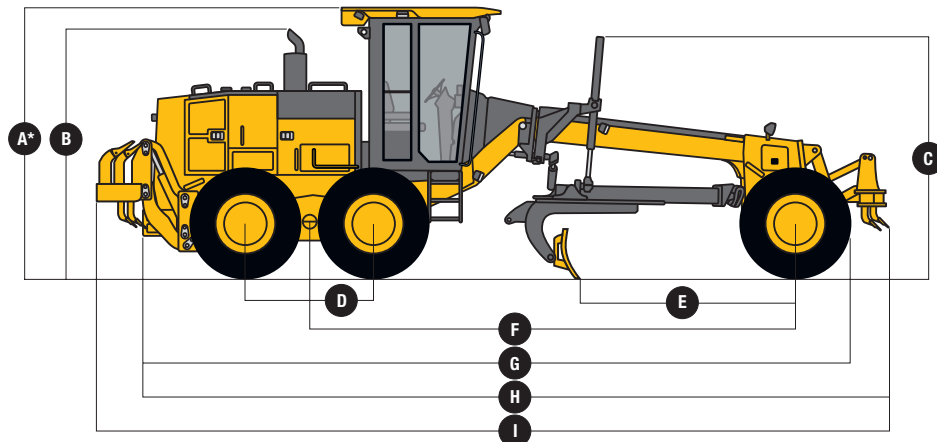

Optional or Special Equipment With Approximate Weights

772D

Add these weights to SAE standard equipment operating weight to obtain total operating weight.

Coolant Heater	8 lb. (4 kg)
Rotary Ejector Precleaner	17 lb. (8 kg)
Lighting Packages	
For Grading (10 halogen lights)	8 lb. (4 kg)
For Grading (10 halogen lights) with LED Turn Signals, Brake Lights, Markers Light, and Hazard Warning Lights	8 lb. (4 kg)
Deluxe for Grading (16 halogen lights)	16 lb. (7 kg)
Deluxe for Grading with 6 Extra LED Colored Lights (16 halogen lights)	17 lb. (8 kg)
Deluxe for Grading with 6 LED Colored Lights (18 halo- gen lights)	20 lb. (9 kg)
High-Front Light Bar for Snowplowing	44 lb. (20 kg)
24- to 12-Volt 30-Amp Converter	3 lb. (1 kg)
Auxiliary Hydraulic Control Valve Section and Controls (optional valves are available for attachments such as rear ripper, front-mounted scarifier, and snow equipment; see dealer price list for details)	15 lb. (7 kg)
Hydraulics for Front-Mounted Equipment	19 lb. (9 kg)
Moldboards with Through-Hardened Dura-Max® Cutting Edge	
12 ft. x 24 in. x $\frac{7}{8}$ in. with 8-in. x $\frac{3}{4}$ -in. cutting edge	100 lb. (45 kg)
12 ft. x 27 in. x 1 in. with 8-in. x $\frac{3}{4}$ -in. cutting edge	277 lb. (126 kg)
13 ft. x 27 in. x 1 in. with 8-in. x $\frac{3}{4}$ -in. cutting edge	396 lb. (180 kg)
14 ft. x 24 in. x $\frac{7}{8}$ in. with 6-in. x $\frac{5}{8}$ -in. cutting edge	231 lb. (105 kg)
14 ft. x 24 in. x $\frac{7}{8}$ in. with 8-in. x $\frac{3}{4}$ -in. cutting edge	346 lb. (157 kg)
14 ft. x 27 in. x 1 in. with 8-in. x $\frac{3}{4}$ -in. cutting edge	554 lb. (251 kg)
Extensions, 2 ft. (610 mm), Right or Left (less cutting edge)	
For Use with 24-in. Moldboards	218 lb. (99 kg)
For Use with 27-in. Moldboards	228 lb. (103 kg)
Overlay End Bits, Reversible (one pair)	
For 6-in. (152 mm) Cutting Edge	42 lb. (19 kg)
For 8-in. (203 mm) Cutting Edge	50 lb. (23 kg)
Extended Wear Moldboard Side-Shift Wear Inserts	8 lb. (4 kg)
Extended Wear Circle Wear Inserts	43 lb. (20 kg)
Bottom Guard, Heavy Duty with Side Guards	391 lb. (177 kg)
Front Weight	550 lb. (249 kg)
Push Block, Front	1,750 lb. (794 kg)
Rear Hitch	50 lb. (23 kg)
Ripper/Scarifier, Rear Mounted with Hitch and Ripper	
Shanks (3)	3,000 lb. (1361 kg)
Scarifier, Front Mounted with Teeth (5)	1,874 lb. (850 kg)
Tires	
14.00-24, 12 PR G2	- 264 lb. (- 120 kg)
17.5-25, 12 PR L2	0 lb. (0 kg)
14.00-R24, Radial, XGLA-2	0 lb. (0 kg)
14.00-R24, Radial, SnoPlus	210 lb. (95 kg)
17.5-R25, Radial, XTLA	132 lb. (60 kg)
17.5-R25, Radial, SnoPlus	306 lb. (139 kg)
17.5-R25, Radial, XHA L3	462 lb. (210 kg)
550/65R25, XTLA 70 L2	900 lb. (408 kg)
Multi-Piece Rims	
10 in. x 24 in.	438 lb. (199 kg)
12 in. x 25 in.	192 lb. (87 kg)
14 in. x 25 in.	561 lb. (254 kg)
Low Cab with Opening Front and Side Windows (air condi- tioning, heater ducts, and 3-in. seat belt)	35 lb. (16 kg)
Tall Cab with Fixed Front and Side Windows (air condition- ing, heater ducts, and 3-in. seat belt)	126 lb. (57 kg)
Tall Cab with Opening Front and Side Windows (air condi- tioning, heater ducts, and 3-in. seat belt)	132 lb. (60 kg)
Canopy, Low Profile with ROPS (3-in. seat belt)	- 356 lb. (- 161 kg)
Deluxe Cloth Seat with Air Suspension and Adjustable Arm- rests and Headrest	28 lb. (13 kg)
Wipers/Washers, Lower-Front Windows	9 lb. (4 kg)

772D MOTOR GRADER

Key: ● Standard equipment ▲ Optional or special equipment

*See your John Deere dealer for further information.

772D Engine

- Meets EPA Tier II non-road emissions regulations
- Self-diagnostic with service-code display
- Rubber isolation mounting to reduce noise and vibration
- Vertical spin-on engine oil filter
- Air-to-air aftercooling for low-engine-speed lugging
- Environmentally friendly engine oil drain valve and hose
- Quick-release dual-stage fuel filter with primer pump
- Fuel/water separator and visual sediment bowl
- Dual air cleaner elements, radial seal, dry type
- Self-draining muffler with curved stack
- Blower-type cooling fan with automatic tensioner
- Variable horsepower
- Electric fuel shutoff
- Safety fan guard
- Extended-life engine coolant -34°F (-37°C)
- Engine coolant surge tank
- Serpentine belt with automatic tensioner
- Glow plugs
- ▲ Engine coolant heater, 1,500 W, 120 volt

Transmission

- John Deere PowerShift Plus™, direct drive, counter-shaft, eight speeds forward and eight speeds reverse
- ▲ Autoshift transmission (gears 4-8)
- Electronic shift modulation
- Over-speed protection
- Self-diagnostic with service-code display
- Industry standard U-shaped shift pattern
- Transmission neutral lock, safety start switch
- Rubber isolation mounting to reduce noise and vibration
- Easy-access vertical spin-on oil filter
- Separate oil lubrication, filtration, and cooling system
- Quick-disconnect transmission test ports

Axle, Final Drive, and Brakes

- Operator-controlled, hydraulically operated differential lock
- Spiral bevel planetary final drives
- Separate oil lubrication, filtration, and cooling system
- Inboard, wet multi-disc brakes
- Primary and secondary brakes, SAE J / ISO 3450
- Spring-applied, hydraulically released parking brake, SAE J / ISO 3450

Electrical

- Heavy-duty, low-maintenance, 1,400 CCA, 440-min. reserve capacity batteries (2)
- ▲ Heavy-duty, low-maintenance, 750 CCA, 180-min. reserve capacity batteries (2)
- 100-amp alternator
- Bypass start safety cover on starter
- Electrical load center
- Individual circuit protection, blade-type fuses
- Electrical master disconnect switch
- Positive terminal battery covers
- High-output halogen transporting lights (4)
- Cab prewired for rotating beacon, radio, and auxiliary circuit
- Electric horn, SAE J1446

772D Electrical (continued)

- Reverse warning alarm, 111 db(A), SAE J994
- Rear stop lights (2)
- Front and rear turn signals (2)
- ▲ Halogen grading lights (10)
- ▲ Deluxe halogen lighting package (16)
- ▲ LED brake and turn lights
- ▲ Deluxe halogen snow package (18)

Hydraulic System

- Separate reservoir, filtration, and cooling system
- 54.7-gpm (207 L/min.) axial-piston main pump
- O-ring face seal fittings
- Float position on blade cylinders
- ▲ Conversion kit from two-hand to one-hand blade lift
- ▲ Hydraulic pump disconnect for cold-weather starting

HFWD

- Effective in gears 1-7
- 15-position aggressiveness control
- Automatically increases tractive effort and steering control
- Axial-piston pumps (2) with separate left and right systems
- Including capability to 0 mph

Blade Functions

- Industry preferred control pattern
- Seven-position saddle
- Four-function hydraulic control valve, right and left
- ▲ Up to six auxiliary function control valves, three right and three left

Draft Frame

- Double ball and socket for extreme-reach positions left and right
- Replaceable wear inserts

Circle

- Nylon wear inserts
- ▲ Extreme-service bronze wear inserts
- 360-degree rotation
- ▲ Circle drive with slip clutch

Moldboard

- 12-ft. x 24-in. x 0.88-in. (3.66 m x 610 mm x 22 mm) high strength, wear resistant
- ▲ 14-ft. x 24-in. x 0.88-in. (4.27 m x 610 mm x 22 mm) high strength, wear resistant
- ▲ 12-ft. x 27-in. x 1-in. (3.66 m x 686 mm x 25 mm) high strength, wear resistant
- ▲ 13-ft. x 27-in. x 1-in. (3.96 m x 686 mm x 25 mm) high strength, wear resistant
- ▲ 14-ft. x 27-in. x 1-in. (4.27 m x 686 mm x 25 mm) high strength, wear resistant
- Standard-duty wear inserts
- ▲ Extreme-service wear inserts

Cutting Edge

- 0.62-in. x 6-in. (16 mm x 152 mm) Dura-Max® through-hardened steel
- ▲ 0.75-in. x 8-in. (19 mm x 203 mm) Dura-Max through-hardened steel

Front Attachments

- ▲ Push block
- ▲ Front weight, 550 lb.

772D Front Attachments (continued)

- ▲ V-type scarifier with float position, five shanks
- ▲ Auxiliary hydraulics for front-mounted equipment

Rear Attachments

- ▲ Ripper/scarifier combination with parallelogram linkage
- ▲ Bottom guard
- ▲ Side panels for bottom guard

Tires and Rims

- Single-piece rims
- ▲ Three-piece rims
- ▲ 14.00-24, 12 PR G2
- ▲ 17.5-25, 12 PR L2
- 14.00-R24, Radial
- ▲ 17.5-R25, Radial
- ▲ 550/65R25

Operator's Station

- Low-profile ROPS cab with air conditioning and heater
- ▲ ROPS canopy
- ▲ Full-height ROPS cab with air conditioning and heater
- Adjustable front console with tilt steering wheel
- Gauges: Fuel level / Engine coolant temperature / Rear steer indicator / Transmission and hydraulic oil temperature
- Monitor system with warning lights: Park brake on / Service brake pressure and/or audible alarm / Hydraulic oil temperature / Transmission oil temperature / Engine oil pressure / Alternator voltage / Differential lock filter restriction / Engine air filter restriction / Wait to start (cold start) / Transmission oil filter restriction / Hydraulic oil filter restriction / Differential lock engaged / Saddle lock pin disengaged / Service code warning
- HFWD charge pressure with audible alarm / HFWD charge filter restriction / HFWD temperature
- Lighted HFWD on-off switch
- Selectable display on monitor: Transmission gear and direction / Vehicle speed (mph) / Vehicle speed (km/h) / Engine speed (rpm) / Hourmeter / Alternator voltage / Service codes
- Indicators: Turn signal / Four-way flasher
- Instrument lights
- Interior lights
- Rearview mirrors (SAE J985): Exterior (2) / Interior
- Deluxe mechanical-suspension seat with adjustable armrests
- ▲ Deluxe air-suspension seat with adjustable armrests
- Retractable seat, 3 in., SAE J386
- Tinted glass
- ▲ Wipers for lower-front windows
- Front and rear windshield washers with intermittent wipers
- ▲ Openable lower-front windows
- ▲ Rear window electrical defroster
- ▲ Radio, AM/FM/weatherband
- ▲ Radio, AM/FM/weatherband with cassette
- ▲ Radio, AM/FM/weatherband with CD
- ▲ Heated outside mirrors
- Floor mat



JOHN DEERE

DKA772D Litho in U.S.A. (05-02)

Net engine power is with standard equipment including air cleaner, exhaust system, alternator, and cooling fan, at standard conditions per SAE J1349 and DIN 70 020, using No. 2-D fuel at 35 API gravity. No derating is required up to 10,000-ft. (3050 m) altitude. Gross power is without cooling fan.

Specifications and design subject to change without notice. Wherever applicable, specifications are in accordance with SAE standards. Except where otherwise noted, these specifications are based on a unit with 14.00-R24, Radial tires; 12-ft. x 24-in. x 0.88-in. (3.66 m x 610 mm x 22 mm) high-strength, wear-resistant moldboard with 0.62-in. x 6-in. (16 mm x 152 mm) Dura-Max through-hardened-steel cutting edge; and standard equipment. Weights include lubricants, coolants, full fuel tank, and 175-lb. (79 kg) operator.

