

# TURBOFARMER II

## TF35.7-115

The mid-range **TF35.7-115 Merlo telehandler** is small on space and big on power.

- ➔ Lowest in-class weight minimises consumption while delivering **max lifting capacity**
- ➔ Improved acceleration and **higher maximum speed** ensures greater productivity
- ➔ **Lower hydraulic pressure** ensures reduced wear and prevents oil over-heating
- ➔ Boom suspension system (BSS) **delivers active dampening** during material handling



SINCE 1964

**BROOKS**  
ACCESS



**MERLO**  
AUSTRALIA

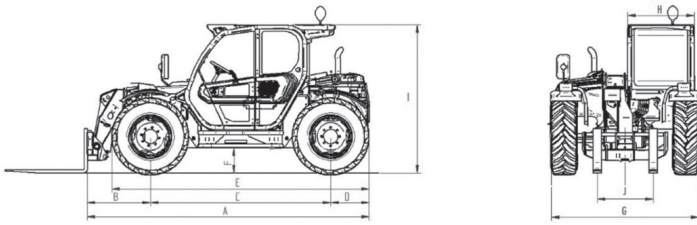

## DIMENSIONS

A (mm)	4,315
B (mm)	990
C (mm)	2,470
D (mm)	585
E (mm)	3,910
F (mm)	380
G (mm)	2,240
H (mm)	995
I (mm)	2,240
J (mm)	850

## PERFORMANCE

Unladen weight (kg)	6,700
Maximum load capacity (kg)	3,500
Maximum lift height (m)	6.6
Capacity at maximum height (kg)	3,500
Maximum reach (m)	3.5
Capacity at maximum reach (kg)	1,350

## Working Times

Ascent (Sec)	6.6
Descent (Sec)	5.5
Extension (Sec)	5
Retraction (Sec)	3.3

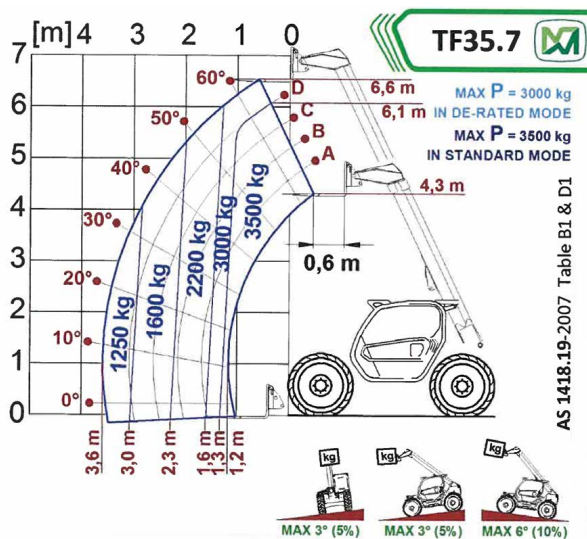

## STANDARD SPECIFICATIONS

### Engine

Turbo engine	Duetz Tier4 Final
Range/Cylinders	3.6/4
Engine power (kW/HP)	90/122
Maximum speed (km/h)	40
Fuel tank capacity (l)	140

### Transmission

Hydrostatic Merlo transmission	EPD
Speeds	2
Dual reverse shuttle system	std
Pedal inching-control	std
Permanent four-wheel drive	std

### Brakes

Automatic parking brake	std
-------------------------	-----

### Tyres

Standard tyres	405/70-24
----------------	-----------

### Cab

Air conditioned cabin	std
Air suspension seat	std
FOPS (ISO 3449) and ROPS (ISO 3471) cab	std

### Steering

All wheel steering	std
--------------------	-----

### Instruments

Electronic joystick control	std
Merlo Dynamic Load Control (M-CDC)	std

### Hydraulic System-Implement

LS flow-sharing hydraulic system (bar-l/min)	210-125
BSS hydro-pneumatic boom suspension	std
Hydraulic oil tank capacity (l)	100
Fan drive pump (l/min)	46
Auxiliary hydraulic service on boom	std

### Dimensions

Width (mm)	2,240
Height (mm)	2,250
Length (mm)	4,315

### Accessories and Attachments

Tac-lock attachment locking	std
Standard forks	std
Fork extensions	Optional
Digging bucket	Optional
Re-handling bucket	Optional
4 x 1 bucket	Optional
Multipurpose bucket with grab	Optional
Crane hook	Optional
Reduced height crane jib	Optional
Drum clamp	Optional
Forks with slide protection	Optional
Handler for single round bale	Optional

## EXTRA SPECIFICATIONS

Two floating forks	std
--------------------	-----

Hire enquirers



**BROOKS**  
ACCESS

☎ **1300 BROOKS** (1300 276 657)  
@ sales@brooksaccess.com.au  
🌐 www.brooksaccess.com.au