

# BROOKS HIRE

*“Better Being With Brooks”*

## KOMATSU

**intelligent** / 2.0  
MACHINE CONTROL

### PC490LC-11 PC490LCi-11

EPA Tier 4 Final Engine  
Australia and New Zealand Specifications



## Hydraulic Excavator

Horsepower  
Gross & NET  
268 kW/359 HP  
@ 1900 rpm

Operating  
weight range  
47,890 - 49,680 kg

Bucket  
Capacity Range  
1.45 - 2.7m<sup>3</sup>

**1300 BROOKS**  
(1300 276 657)  
[sales@brookshire.com.au](mailto:sales@brookshire.com.au)

CERTIFIED  
ISO 9001  
ISO 14001  
ISO 45001





# Greater performance and Faster cycle times

NET Horsepower

**268 kW/ 359 HP @ 1900 rpm**

Operating weight

**47,890 – 49,680 kg**

Bucket capacity

**1.45 – 2.7 m<sup>3</sup>**



Photos may include optional equipment.

## Komatsu's Closed-centre Load Sensing System (CLSS)

provides quick response and smooth operation to maximise productivity.

\*All Models

## New engine and hydraulic control technology

improves operational efficiency and lowers fuel consumption by up to 11%.

**A powerful Komatsu SAA6D114E-6 engine** provides a net output of 192 kW 257 HP. This engine is EPA Tier 4 Final emissions certified.

**Komatsu Variable Geometry Turbocharger (KVGT)** uses a hydraulic actuator to provide optimum air flow under all speed and load conditions.

**Komatsu Diesel Particulate Filter (KDPF) and Selective Catalytic Reduction (SCR) system** reduce particulate matter and NOx while providing automatic regeneration that does not interfere with daily operation.

**Large displacement high efficiency pumps** provide high flow output at lower engine speed, improving efficiency.

**Two boom mode settings** provide power mode for maximum digging force or smooth mode for fine grading operations.

**Komtrax<sup>®</sup>** equipped machines can send location, SMR and operation maps to a secure website or smart phone utilising wireless technology. Machines also relay error codes, cautions, maintenance items, fuel and Diesel Exhaust Fluid (DEF) levels, and much more.

## Komatsu designed and manufactured components

**Handrails (standard)** located on the machine upper structure provide a convenient work area in front of the engine.

**Lockable single pole battery isolation switch** allows a technician to disconnect the power supply before servicing the machine.

**Heavy duty boom** design with large one piece castings provide increased strength and durability.

**Komatsu Auto Idle Shutdown** helps reduce nonproductive engine idle time and reduces operating costs.

**Operator Identification System** records Komtrax<sup>®</sup> machine operation and application data for up to 100 individual ID codes.

## Large LCD colour machine monitor:

- 7" high resolution display
- Enhanced hydraulic attachment control with one way/two way flow and programmable work tool names and settings
- Key machine settings and controls easily accessible through the monitor.

**Rearview monitoring system (standard)** with integrated camera display in the default monitor screen.

**KomVision (standard)** are designed to match engine speed, pump delivery and system pressure to the application.

## Enhanced working environment:

- High back, heated air suspension seat with new adjustable arm rests
- Integrated ROPS cab design
  - Conforms to [ISO 12117-2] for excavators, also satisfies Level 1 operator Protective Guard [OPG] and Top guard [ISO 10262]
- AUX jack and [2] 12V power outlets.





## Komatsu new engine technologies

### Komatsu's new emission regulations-compliant engine

New regulations effective in 2018 require the reduction of NOx emissions to one tenth or below from the preceding regulations. In addition to refining the Tier 4 Interim technologies, Komatsu has developed a new Selective Catalytic Reduction (SCR) device in-house.

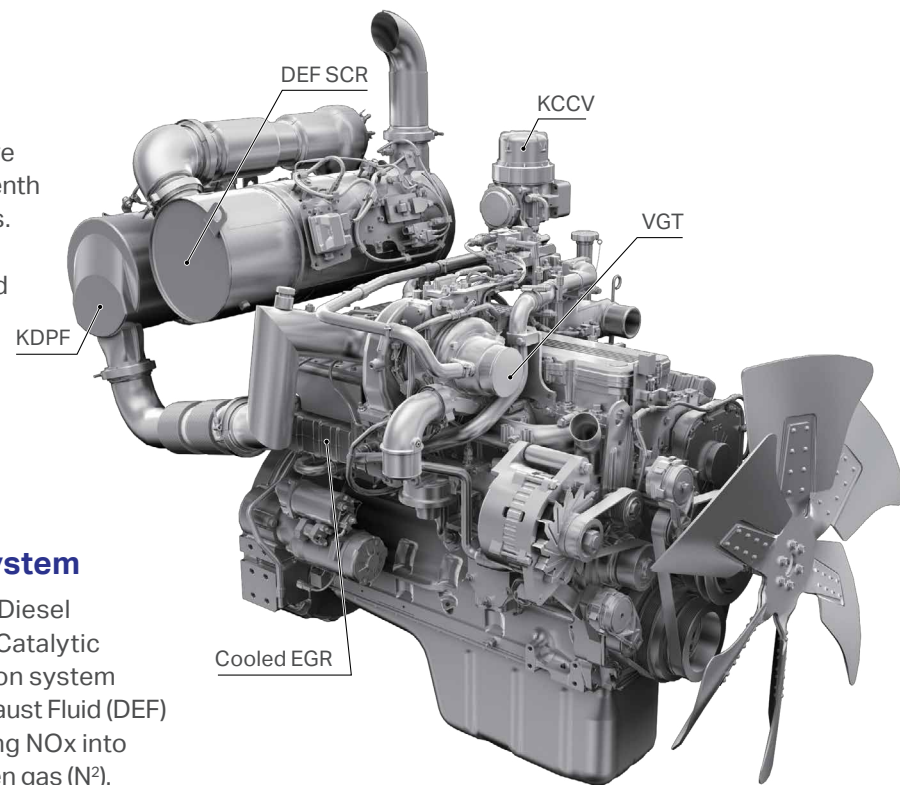

### Technologies applied to new engine

#### Heavy-duty aftertreatment system

This new system combines a Komatsu Diesel Particulate Filter (KDPF) and Selective Catalytic Reduction (SCR). The SCR NOx reduction system injects the correct amount of Diesel Exhaust Fluid (DEF) at the proper rate, thereby decomposing NOx into non-toxic water vapour (H<sub>2</sub>O) and nitrogen gas (N<sub>2</sub>).

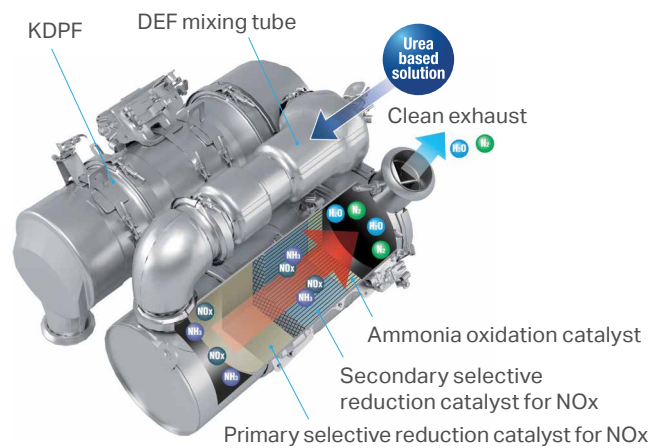

#### Heavy-duty cooled Exhaust Gas Recirculation (EGR) system

The system recirculates a portion of exhaust gas into the air intake and lowers combustion temperatures, thereby reducing NOx emissions. EGR gas flow has been decreased for Tier 4 Final with the addition of SCR technology.

The system achieves a dynamic reduction of NOx, while helping reduce fuel consumption below Tier 4 Interim levels.

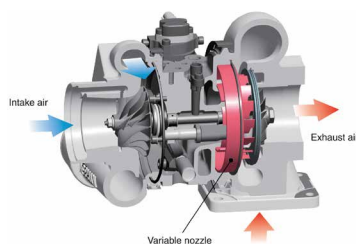

#### Advanced electronic control system

The electronic control system performs high-speed processing of all signals from sensors installed in the vehicle providing total control of equipment in all conditions of use. Engine condition information is displayed via an on-board network to the monitor inside the cab, providing necessary information to the operator. Additionally, managing the information via Komtrax® helps customers keep up with required maintenance.

#### Komatsu Variable Geometry Turbocharger (KVGT) system

The VGT system features proven Komatsu design hydraulic technology for variable control of air-flow and supplies optimal air according to load conditions. The upgraded version provides better exhaust temperature management.

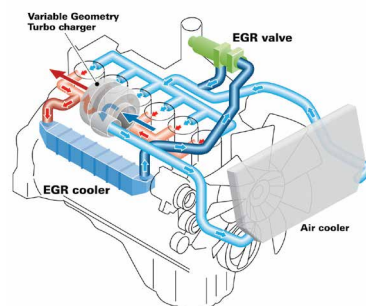

### Komatsu auto idle shutdown

Komatsu auto idle shutdown automatically shuts the engine down after idling for a set period of time to reduce unnecessary fuel consumption and exhaust emissions.



### Heavy-Duty High-Pressure Common Rail (HPCR) fuel injection system

The system is designed to achieve an optimal injection of high-pressure fuel by means of computerised control, providing close to complete combustion to reduce PM emissions. While this technology is already used in current engines, the new system uses high pressure injection, thereby reducing both PM emissions and fuel consumption over the entire range of engine operating conditions. The Tier 4 Final engine has advanced fuel injection timing for reduced fuel consumption and lower soot levels.

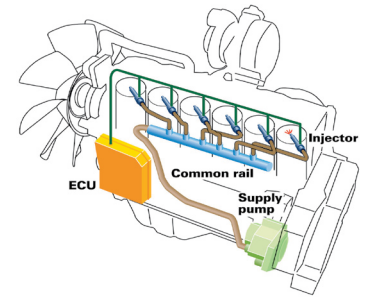



## Performance features

### Reduced fuel consumption

The PC490LC-11's enhanced P Mode provides more hydraulic flow and increases productivity.

#### Fuel consumption

### Up to 13% Increase

(compared to the PC450LC-8 in standard P Mode)

P mode (90° swing and loading onto truck)

- |                                    |                                 |
|------------------------------------|---------------------------------|
| 1 Large counterweight              | 7 HD carrier rollers and idlers |
| 2 High capacity swing bearing      | 8 Reinforced crawler frames     |
| 3 Reinforced track links and shoes | 9 Reinforced revolving frame    |
| 4 Large final drive                | 10 Track roller guards          |
| 5 HD sprockets                     | 11 Deck guard                   |
| 6 Reinforced centre frame          | 12 Centre frame swivel guard    |

### Increased work efficiency

#### Large digging force

With the one-touch Power Max. function, digging force is increased for 8.5 seconds of operation.

#### Maximum arm crowd force (ISO)

200 kN(20.4t) ➔ 214 kN(21.8t) **7% UP**  
(With Power Max.)

#### Maximum bucket digging force (ISO)

256 kN(26.1t) ➔ 275 kN(28.0t) **7% UP**  
(With Power Max.)

Measured with Power Max. function, 3400 mm arm and ISO rating.



### Hydraulic variable speed fan

The electronic control system sets the rotation speed of the cooling fan according to the coolant, hydraulic oil, and ambient temperatures; effectively uses the engine output to reduce wasteful fuel consumption; and reduces noise during low-speed fan operation.

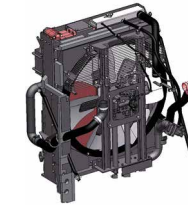

### Efficient hydraulic system

The PC490LC-11 uses a Closed Centre Load Sensing (CLSS Hydraulic System that improves fuel efficiency and provides quick response to the operator's demands.) The PC490LC-11 also incorporates new technology to enhance the engine and hydraulic pump control. This total control system matches the engine and hydraulics at the most efficient point under any load condition. There have also been improvements in the main valve and hydraulic circuit to reduce hydraulic loss, resulting in higher efficiency and lower fuel consumption.

### Large displacement high efficiency pump

Large displacement hydraulic implement pumps provide high flow output at lower engine RPM as well as operation at the most efficient engine speed.



### Faster arm cycle speeds

Two return hoses improve arm cylinder hydraulic flow for faster arm out performance.

### Two-mode settings for boom

- Smooth boom mode provides easy operation for gathering material or scraping down.
- Power boom mode maximises digging force for more effective excavating.

### Working mode selection

The PC490LC-11 excavator is equipped with six working modes (P, E, L, B, ATT/P and ATT/E). Each mode is designed to match engine speed, pump flow, and system pressure to the application. The PC490LC-11 features an attachment mode (ATT/E) that allows operators to run attachments while in Economy mode.

Working mode	Application	Advantage
<b>P</b>	Power Mode	Maximum production/ power & Fast cycle times
<b>E</b>	Economy Mode	Good cycle times & Better Fuel Economy
<b>L</b>	Lifting Mode / Fine Control	Increases Hydraulic Pressure
<b>B</b>	Breaker Mode	Optimum engine RPM, hydraulic flow
<b>ATT/P</b>	Attachment Power Mode	Optimum engine rpm, hydraulic flow, 2-way Power mode
<b>ATT/E</b>	Attachment Economy Mode	Optimum engine rpm, hydraulic flow, 2-way Economy mode

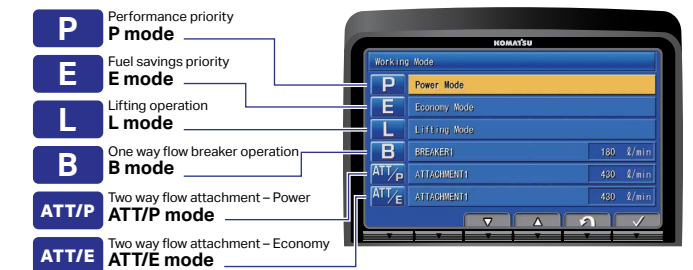

### High rigidity work equipment

Booms and arms are constructed with thick plates of high tensile strength steel. In addition, these structures are designed with large cross sectional areas and large one piece castings in the boom foot, the boom tip, and the arm tip. The result is work equipment that exhibits long term durability and high resistance to bending and torsional stress. A standard HD boom design provides increased strength and reliability.

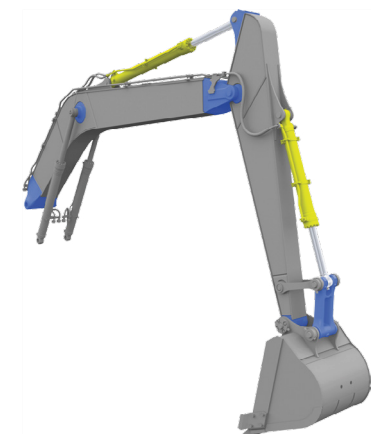



# Working environment



## Comfortable working space

### Wide, spacious, pressurised cab

Wide spacious cab includes seat with reclining backrest. The seat height and longitudinal inclination are easily adjusted using a pull-up lever. You can set the appropriate operational posture of armrest together with the console. Reclining the seat further enables you to place it into the fully flat state with the headrest attached.

### Arm rest with simple height adjustment function

The addition of a knob and a plunger to the armrest permits the height of the armrest to be easily adjusted without the use of tools.



Low vibration with cab damper mounting  
Automatic climate control.

### IMC 2.0 UHF and network antenna

UHF and Network Antenna - providing corrections, service and Remote support capability.



## Standard equipment

Sliding window glass (left side)



AM/FM Bluetooth radio



Remote intermittent wiper with windshield washer



Emergency stop and level indicator



ISO Level 2 OPG



Magazine box and cup holder



Defroster (conforms to the ISO standard)



One-touch storable front window lower glass





# Working environment

## Large high resolution LCD monitor



### New monitor panel interface design

An updated large high resolution LCD colour monitor enables accurate and smooth work. The interface has been redesigned to display key machine information in a new user friendly interface. A rear view camera and a DEF level gauge display have been added to the default main screen. The interface has a function that enables the main screen mode to be switched, thus enabling the optimum screen information for the particular work situation to be displayed.

#### Indicators

- |                                    |                             |
|------------------------------------|-----------------------------|
| 1 Auto-decelerator                 | 8 Fuel gauge                |
| 2 Working mode                     | 9 DEF level gauge           |
| 3 Travel speed                     | 10 Service metre, clock     |
| 4 Ecology gauge                    | 11 Fuel consumption gauge   |
| 5 Camera display                   | 12 Guidance icon            |
| 6 Engine coolant temperature gauge | 13 Function switches        |
| 7 Hydraulic oil temperature gauge  | 14 Camera direction display |
|                                    | 15 DEF level caution lamp   |

#### Basic operation switches

- |                         |                         |
|-------------------------|-------------------------|
| 1 Auto-decelerator      | 5 Wiper                 |
| 2 Working mode selector | 6 Window washer         |
| 3 Travel speed selector | 7 Auto climate controls |
| 4 Buzzer cancel         |                         |

### Visual user menu

Pressing the F6 key on the main screen displays the user menu screen. The menus are grouped for each function, and use easy-to-understand icons which enable the machine to be operated easily.

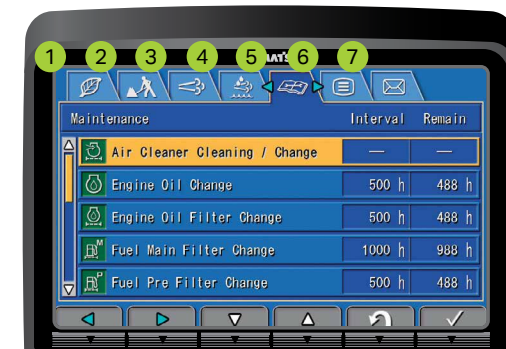

- |                                       |                   |
|---------------------------------------|-------------------|
| 1 Energy saving guidance              | 4 SCR information |
| 2 Machine settings                    | 5 Maintenance     |
| 3 Aftertreatment devices regeneration | 6 Monitor setting |
|                                       | 7 Message check   |

### KomVision

Images from 4 camera's are combined to display a "birds eye" view of the area around the machine for improved operator awareness. A second display with selectable individual camera views of the left, rear, and right sides is easily changed using the F4 button. A red line continuously shows where the counterweight will be during swinging and a camera icon indicates which camera is being displayed on individual camera display screen.



## Support efficiency improvement

### Ecology gauge and fuel consumption gauge

The monitor screen is provided with an ecology gauge and also a fuel consumption gauge which is displayed continuously.

In addition, the operator can set any desired target value of fuel consumption (within the range of the green display), enabling the machine to be operated with better fuel economy.



Ecology gauge Fuel consumption gauge

### Operator identification function

An identification ID can be set up for individual operator, application or jobs, and used to manage operation information of individual machines using Komtrax® data. Data sent from Komtrax® can be used to analyse operation status by operator as well as by machine.



### Ecology guidance

While the machine is operating, ecology guidance pops up on the monitor screen to notify the operator of the status of the machine in real time.

### Operation record, fuel consumption history, and ecology guidance record

The ecology guidance menu enables the operator to check the operation record, fuel consumption history and ecology guidance record from the ecology guidance menu, using a single touch, thus enabling the total fuel consumption to be reduced.



Operation record



Fuel consumption history



Ecology guidance record



## intelligent MACHINE CONTROL 2.0

### Make every pass count

Improve your efficiency – intelligent Machine Control means fast excavation to finish grade.

Semi-automatic operation – new features such as bucket angle hold control provide high levels of accuracy and comfort.



### Innovative

- intelligent Machine Control excavator features semi-automatic operation of work equipment for highly accurate work.

**NEW**

- Compact 10.4" iMC monitor with increased memory capacity, processing speed, and pinch to zoom capability.

### Integrated

- Complete factory-installed and integrated intelligent Machine Control system comes standard with stroke sensing hydraulic cylinders.
- Multiple Global Navigation Satellite System (Multi-GNSS) components and an Inertial Measurement Unit (IMU) sensor. All components are validated to Komatsu's rigid quality and durability standards.
- Multi-band UHF/915SS radio improves job site flexibility.
- 3G/4G LTE connectivity for fast reliable job site connectivity.
- DUHF II Radio Standard fitment & 915SS Optional equipment – offers improved jobsite flexibility.

**NEW**

**NEW**

**NEW**

**NEW**

### Intelligent

- intelligent Machine Control excavator allows the operator to focus on moving material efficiently while semi-automatically tracing the target surface and limiting over-excavation.
- Facing angle compass, light bar and sound guidance aid in ease of operation and bucket positioning.
- Bucket Angle Hold and optional Auto-Tilt Attachment Control increase ease of operation and improve productivity and efficiency.

**NEW**



## intelligent Machine Control



### intelligent Machine Control

intelligent Machine Control is based on Komatsu's unique sensor package, including stroke sensing hydraulic cylinders, an IMU sensor, and GNSS antennas. It utilises 3D design data loaded in the control box to accurately check its position against the target. If the bucket hits the target surface, it is semi-automatically limited to minimise over-excavation. If the operator turns off Auto mode, the machine can be operated with highly accurate, responsive machine guidance, with the machine only providing indication guidance.



#### • Auto grade assist

With the auto grade assist function, the operator moves the arm, the boom adjusts the bucket height automatically, tracing the target surface and minimising digging too deep. This allows the operator to perform rough digging without worrying about the design surface, and to perform fine digging by operating the arm lever only. The working range is extended by holding the lever to move the boom downward.



#### • Auto stop control

During boom or bucket operation, the work equipment automatically stops when the bucket edge reaches the design surface, thus minimising damage to the design surface.



#### • Minimum distance control

The intelligent Machine Control excavator controls the bucket by automatically selecting the point on the bucket closest to the target surface. Should the machine not be facing a sloped surface at a right angle, it will still follow the target surface and minimise digging below it.



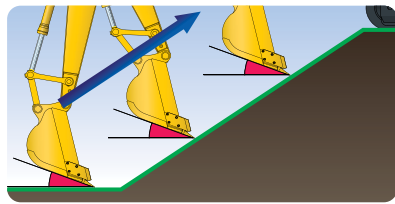

NEW

**Bucket angle hold control**

Operator sets desired bucket angle and the system automatically maintains bucket angle throughout the grading pass. Angle hold control increases ease of operation and improves final grading accuracy.

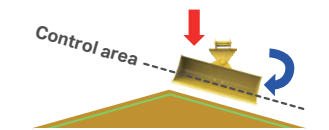

**Operation:** Arm IN or Boom DOWN  
**Control:** Bucket TILT

NEW

**Auto-tilt Attachment Control**

Automatically tilts bucket to design surface and returns it to horizontal to unload. Using auto tilt control with the existing minimum distance control and auto grade assist makes complex grading quicker and easier.

**Improved construction efficiency**

Staking, survey and final inspection (which is usually done manually), can be reduced with the intelligent Machine Control excavator by setting 3D design data on the control box. Also, use of the facing angle compass can minimise leveling work for the surface on which the machine sits. Even if the machine is inclined while working, the facing angle compass allows the operator to ensure that the machine is facing perpendicular to the target surface. The intelligent Machine Control technology allows the operator to improve work efficiency (i.e. shorter construction time) while minimising over-excavating the target surface from rough digging to finish grading.

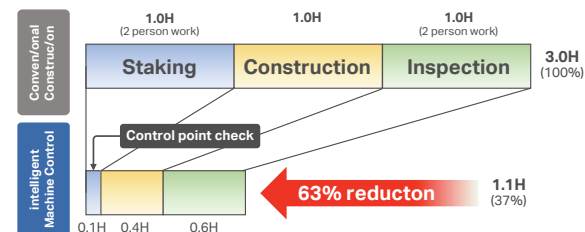

\* When used by a qualified iMC operator, the Komatsu intelligent Machine Control system increases construction efficiency.  
\* The above data does not include design time or working data creation time. The above data is based on in-house construction tests, performed by Komatsu, whose conditions may differ from actual construction.

**Improved work accuracy**

The bucket edge/tip position is instantly displayed on the control box, eliminating the wait time for display on the monitor during construction. The large and easy-to-view control box displays information clearly, aiding in highly accurate work. With manual operation and conventional machine guidance, finish grade quality and excavating accurately depends heavily on the skill of the operator. With the intelligent Machine Control excavator, the bucket is automatically limited to follow the target grade without over-excavating.

**Relationship between finished surface and allowable value**

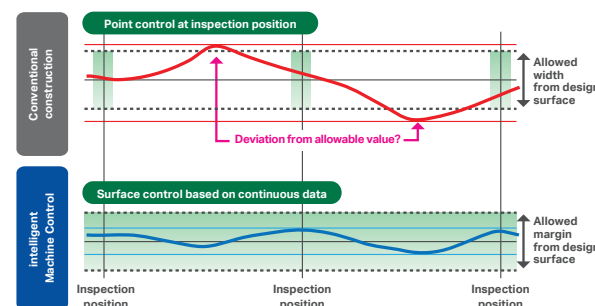

**As-built surface mapping**

Operator can display and check the as-built status and find where to cut and fill.



# intelligent Machine Control

**Control box**

The monitor of the Komatsu intelligent Machine Control (control box) uses a compact 10.4" screen for visibility and ease of use. The simple screen layout displays the necessary information in an easily understood fashion. Touch screen icon interface instead of multi-step menu simplifies operation.

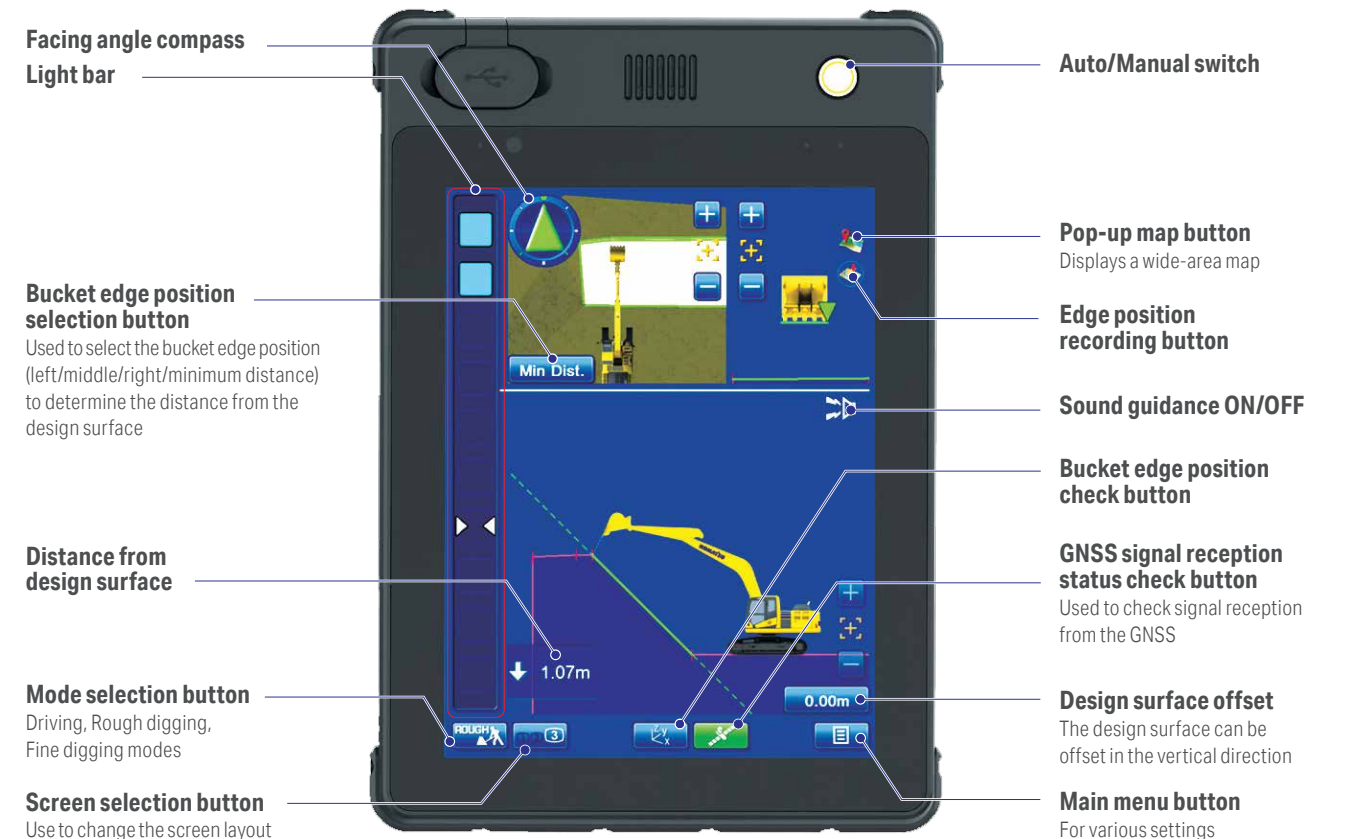

**Preset Elevation Offset Quick Button** +0.500'

Pre-determined offsets can be stored in the monitor to allow an operator to easily switch between preset grades.

NEW

Offset preset	0.000'	Apply
	0.500'	Apply
	1.500'	Apply

Button switch mode: Offset preset

**Quick Bucket Swap Button** NEW

Allows users to quickly swap between various buckets without having to enter main menu. This lessens the time a user takes to change out a bucket on the monitor.

**Machine navigation**

**Facing angle compass**

The orientation and colour of the facing angle compass's arrow shows the operator the facing angle of the bucket edge relative to the target surface.



This allows the bucket edge to be accurately positioned square with the target surface, which is useful when finishing slopes.

**Enhanced operability of the machine control**

Semi-auto/manual mode switching and design surface offset function can be operated with switches on the control levers.



NEW



## Factory installed Komatsu intelligent Machine Control components



**Control box**  
A large, easy-to-view monitor and unique interface designed for Komatsu intelligent Machine Control excavators.

**Stroke sensing hydraulic cylinders**  
Integrated stroke sensing cylinders provide accurate real time bucket position which is immediately displayed on the control box providing increased productivity and accuracy.

**GNSS antennae**

**GNSS receiver**

**Inertial Measurement Unit (IMU)**  
The IMU detects machine pitch and roll for highly accurate finishing work regardless of ground condition.

**Auto-tilt attachment control**



## Work smarter from rough digging to finish grade

Give your operators the power to work more effectively than with conventional aftermarket machine guidance (indicate only) or manual operation. Intelligent Machine Control (iMC) excavators with semi-automatic control offer the capability to work smart from rough digging to finish grading, and help minimise over-excavation to make every pass count.

- Semi-automatic for trenching, slope work and high production applications
- Protection + precision + performance = the formula for pursuing maximum productivity versus conventional machine guidance



Photos may include overseas specification.

### Standard local options providing first 12 months support:

(includes: Standard 3G/4G modem with DATA & SIM, industry leading ICT machine OEM service support agreement with iMC 2.0)



**Remote control**  
Assist the operator by taking control of their GNSS equipment in real-time.



**File transfer history**  
Overview of when, and which, files have been transferred.



**Remote view**  
Real-time remote image of the GNSS equipment.



**Office to machine transfer**  
Send the latest design files from the office to your machines.



**Machine to office transfer**  
Download files that have been collected on your system (survey results, as-built data, ...)



**Offline file transfer**  
Machine offline? No issue. Files are stored in cloud, operator will see updated model at machine switch on.



**Batch file transfer**  
Send files to multiple machines in one click.





# Working smarter in every way

## Benefits of iMC 2.0



### Save money

Frees GPS Dozer from need to achieve final grade so it can work elsewhere on the site.



### Save time

Reduce staking, grading and inspection with 3D design data and semi-automatic grading.

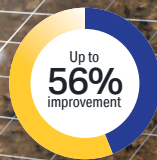

### Less time grade checking

Monitor performance and stay on grade from the cab: operators spend time working, not grade checking.

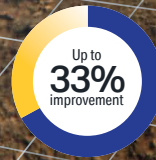

### Improve accuracy

Continuously monitor grade and semi-automatics to dig precisely to grade.

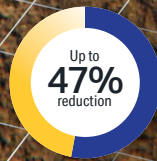

### Reduce base aggregate

Greatly reduce over-digging and the amount of costly base aggregate needed for applications like utilities.

*\*All savings, improvements, and reductions are compared to traditional grading methods.*

Photo may include overseas specification.

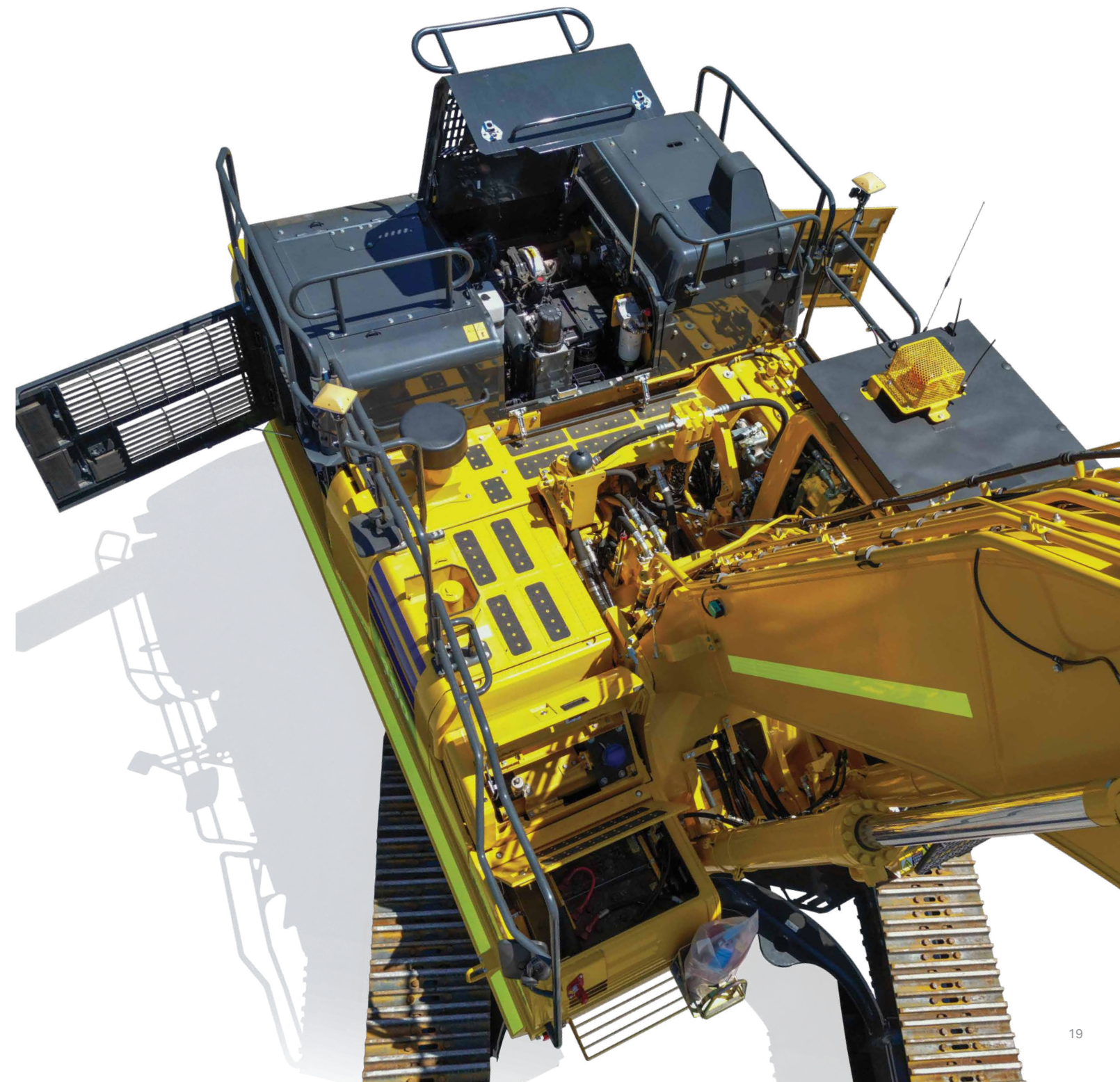

## Maintenance features



## Maintenance features

### Centralised engine check points

Locations of the engine oil check and filters are integrated into one side to allow easy maintenance and service.



### Battery isolation switch

A standard battery isolation switch allows a technician to disconnect the power supply and lock out before servicing the machine.



### Easy cleaning of cooling unit

Reverse-rotation function of the hydraulic driven fan facilitates cleaning of the cooling unit.

### Fuel pre-filter with water separator

### High efficiency fuel filter

Easy access to engine oil filter, engine oil, Ecology drain valve, fuel drain valve and water separator drain valve

### Cab air filter

### Washable cab floormat

### Sloping track frame

### DT-type connectors

Sealed DT-type electrical connectors provide high reliability, water and dust resistance.

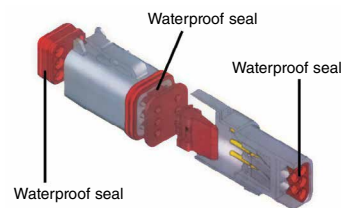

### Long-life oils, filters

High performance filters are used in the hydraulic circuit and engine. By increasing the oil and filter replacement intervals, maintenance costs can be significantly reduced.



Hydraulic oil filter (Ecology-white element)

Engine oil & Engine oil filter every **500** hours

Hydraulic oil every **5000** hours

Hydraulic oil filter every **1000** hours

### Large capacity air cleaner

Large capacity air cleaner is comparable to that of larger machines. The larger air cleaner can extend air cleaner life during long-term operation and helps prevent early clogging, and resulting power loss. A radial seal design is used for reliability.



### Diesel Exhaust Fluid (DEF) tank

A large tank volume extends operating time before refilling and is installed on the right front stairway for ease of access.

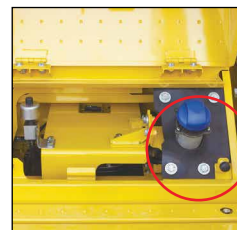

## General features

### ROPS cab structure ROPS Cab (ISO 12117-2)

The machine is equipped with a ROPS cab that conforms to ISO 12117-2 for excavators as standard equipment. It also satisfies the requirements for Level 1 Operator Protective Guard (OPG) and top guard (ISO 10262).



### Low vibration with viscous cab mounts

The PC360LC-11 uses viscous mounts for the cab that incorporate a longer stroke and the addition of a spring. The cab damper mounting combined with a high rigidity deck reduces vibration at the operator's seat.

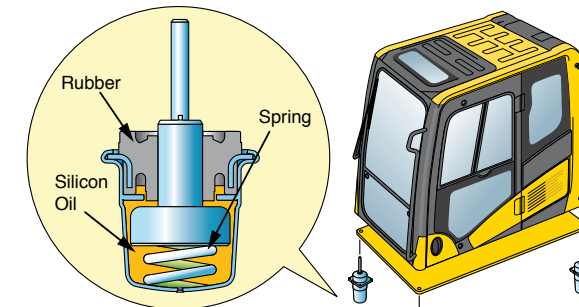

## General features

- Secondary engine shut down switch at base of seat to shutdown the engine
- Seat belt caution indicator
- Lock lever
- Retractable seat belt
- Tempered & tinted glass
- Large cab entrance step
- Left and right side hand rails
- Large mirrors
- Slip-resistant plates
- Thermal and fan guards
- Pump/engine compartment partition
- Travel alarm



## Maintenance Information



### “Maintenance time caution lamp” display

When the remaining time to maintenance becomes less than 30 hours\*, a maintenance time monitor appears. Pressing the F6 key switches the monitor to the maintenance screen.

\* : The setting can be changed within the range between 10 and 200 hours.

### Manual Stationary Regeneration

Under most conditions, active regeneration will occur automatically with no effect on machine operation. In case the operator needs to disable active regeneration or initiate a manual stationary regeneration, this can be easily accomplished through the monitor panel. A soot level indicator is displayed to show how much soot is trapped in the KDPF.

### Supports the DEF level and refill timing

The DEF level gauge is displayed continuously on the right side of the monitor screen. In addition, when DEF level is low, DEF low level guidance messages appear in pop up displays to inform the operator in real time.



## KALSS Australian standard specification



**Rotating amber beacon**  
Fitted with factory guard.



**Level indicator, overload alarm & anti-burst valves**  
Enable safety and compliance when lifting suspended loads.



**Additional lighting**  
Extra lighting on cab and counterweight for improved visibility.



**Proportional hand controls**  
Enables proportional hand control of attachment speed.

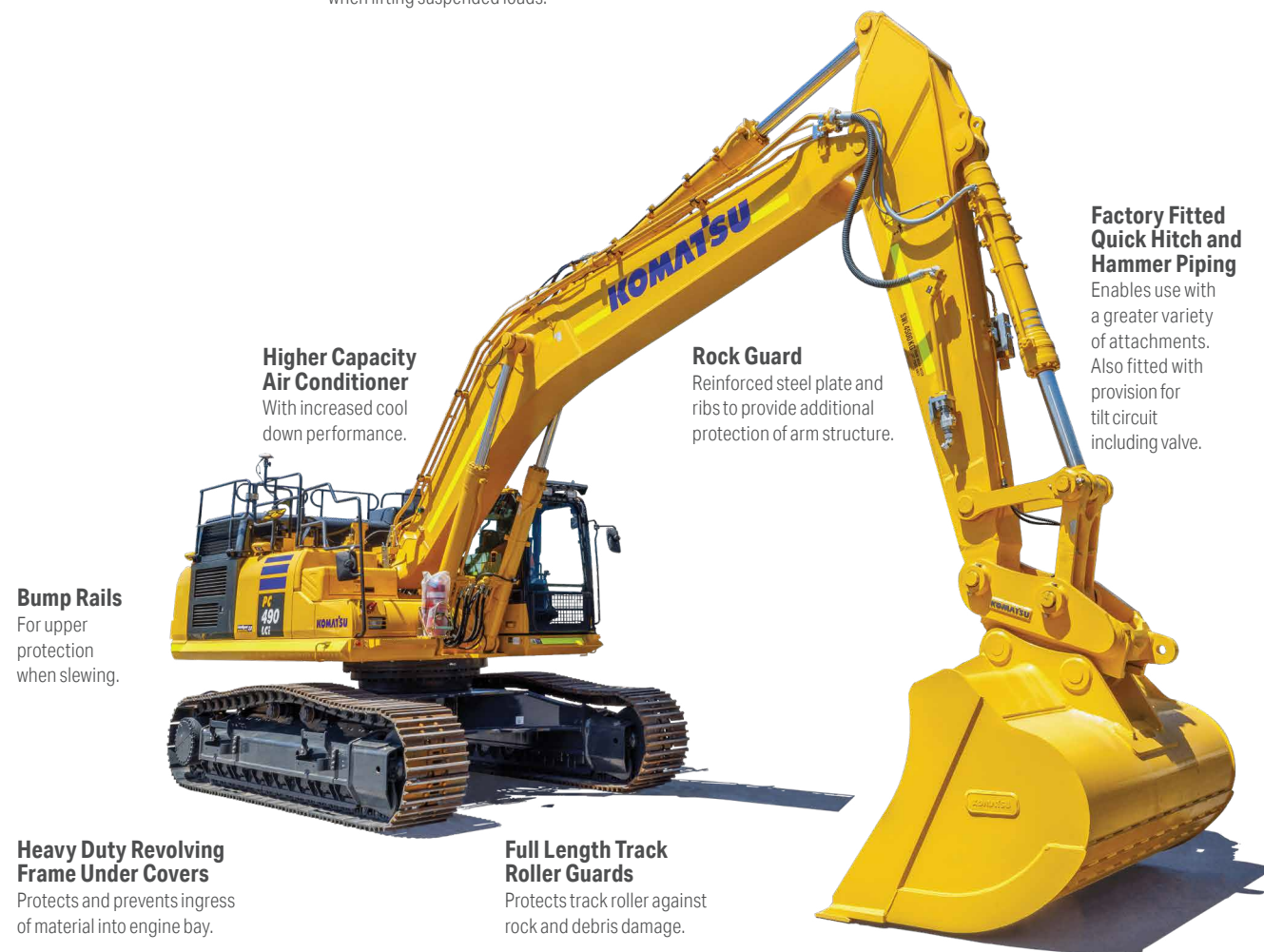

**Higher Capacity Air Conditioner**  
With increased cool down performance.

**Rock Guard**  
Reinforced steel plate and ribs to provide additional protection of arm structure.

**Factory Fitted Quick Hitch and Hammer Piping**  
Enables use with a greater variety of attachments. Also fitted with provision for tilt circuit including valve.

**Bump Rails**  
For upper protection when slewing.

**Heavy Duty Revolving Frame Under Covers**  
Protects and prevents ingress of material into engine bay.

**Full Length Track Roller Guards**  
Protects track roller against rock and debris damage.



**Lower Front Window Guard**  
Protects cabin windscreen against rocks and debris.



**Battery Isolation**  
Single pole, lockable Bosch-type battery isolation.



**E-Stops**  
Allow compliance to site safety requirements.



**Bolt-on Top Guard**  
OPG Level 2 (ISO 10262) for falling object protection.

Specification also includes factory fitted provisions for fire extinguisher, turbo timer, UHF and vandal covers to reduce lead times and costs. Photos may include optional equipment.

## Specifications

### ENGINE

Model	Komatsu SAA6D125E-7*
Type	Water-cooled, 4-cycle, direct injection
Aspiration	Variable geometry turbocharged, aftercooled, cooled EGR
Number of cylinders	6
Bore	125 mm 4.92"
Stroke	150 mm 5.91"
Piston displacement	11.04 ltr 674 in <sup>3</sup>
Horsepower:	
SAE J1995	Gross 270 kW 362 HP
ISO 9249 / SAE J1349	Net 268 kW 359 HP
Rated rpm	1900
Governor	All-speed control, electronic
Fan drive method for radiator cooling	Hydraulic

\*EPA Tier 4 Final emissions certified

### HYDRAULICS

Type	HydraMind (Hydraulic Mechanical Intelligence) system, closed-centre system with load sensing valve and pressure compensated valves, 6 selectable working modes		
Main pump:			
Pumps for	Boom, arm, bucket, swing, and travel circuits		
Type	Variable displacement axial piston type		
Maximum flow	780 ltr/min 206 gal/min		
Hydraulic motors:			
Travel	2 x axial piston motor with parking brake		
Swing	1 x axial piston motor with swing holding brake		
Relief valve setting:			
Implement circuits .....	37.3 MPa	380 kgf/cm <sup>2</sup>	5,400 psi
Travel circuit .....	37.3 MPa	380 kgf/cm <sup>2</sup>	5,400 psi
Swing circuit .....	27.9 MPa	285 kgf/cm <sup>2</sup>	4,050 psi
Pilot circuit .....	3.2 MPa	33 kgf/cm <sup>2</sup>	470 psi

Boom	2-160 mm x 1570 mm x 110 mm 6.3" x 61.8" x 4.3"		
Arm	1-185 mm x 1820 mm x 120 mm 7.3" x 71.7" x 4.7"		
Bucket	1-160 mm x 1270 mm x 110 mm 6.3" x 50" x 4.3"		

### DRIVES AND BRAKES

Steering control	Two lever with pedals
Drive method	Hydrostatic
Maximum drawbar pull	329 kN 33510 kgf 73,880 lbf
Gradeability	70%, 35°
Maximum travel speed (auto shift):	
High	5.5 km/h 3.4 mph
Mid	4.2 km/h 2.6 mph
Low	3.0 km/h 1.9 mph
Service brake	Hydraulic lock
Parking brake	Mechanical disc

### SWING SYSTEM

Driven by	Hydraulic motor
Swing reduction	Planetary gear
Swing circle lubrication	Grease-bathed
Service brake	Hydraulic lock
Holding brake/Swing lock	Mechanical disc brake
Swing speed	9.1 rpm
Swing torque	13414 kg•m 97,024 ft lbs

### UNDERCARRIAGE

Centre frame	X-frame
Track frame	Box-section
Track type	Sealed
Track adjuster	Hydraulic
Number of shoes (each side)	49
Number of carrier rollers (each side)	2
Number of track rollers (each side)	8

### COOLANT & LUBRICANT CAPACITY

Fuel tank	650 ltr 172 U.S. gal
Radiator	47.0 ltr 12.4 U.S. gal
Engine	38 ltr 10.0 U.S. gal
Final drive, each side	11.0 ltr 2.9 U.S. gal
Swing drive	20.0 ltr 5.3 U.S. gal
Hydraulic tank	248 ltr 65.5 U.S. gal
Diesel Exhaust Fluid (DEF) tank	39 ltr 10.3 U.S. gal

### OPERATING WEIGHT (APPROXIMATE)

Operating weight includes 7000 mm one-piece HD boom, 3400 mm arm, rated capacity of lubricants, coolant, full fuel tank, operator, standard equipment, KGA dual lock quick hitch, and SAE heaped 2.5 m<sup>3</sup> bucket.

Triple-Grouser Shoes	Operating Weight	Ground Pressure
600 mm	48,690 kg	0.86 kg/cm <sup>2</sup>
700 mm	49,190 kg	0.65 kg/cm <sup>2</sup>
800 mm	49,680 kg	0.58 kg/cm <sup>2</sup>

### Component Weights

Arm including bucket cylinder and linkage 3400 mm 11"1" arm assembly	2141 kg	4,720 lb
One piece HD boom including arm cylinder 7000 mm 23'2" boom assembly	4017 kg	8,856 lb
Boom cylinders x 2	366 kg	807 lb
Counterweight (standard)	9570 kg	21,098 lb



**Dimensions**

<b>Arm Length</b>	<b>3400 mm</b>
A Overall length	11930 mm
B Length on ground (transport)	6705 mm
C Overall height (to top of boom)*	3635 mm
D Overall width	3565 mm
E Overall height (to top of cab)*	3360 mm
F Overall height (to top of handrail)*	3450 mm
G Ground clearance, counterweight	1385 mm
H Ground clearance, minimum	568 mm
I Tail swing radius	3645 mm
J Track length on ground	4350 mm
K Track length	5385 mm
L Track gauge	2740 mm
M Width of crawler	3340 mm
N Shoe width	600 mm
O Grouser height	37 mm
P Machine height to top of engine cover	3630 mm
Q Machine upper width**	3360 mm
R Distance, swing centre to rear end	3605 mm

\* : Including grouser height      \*\* : Including handrail

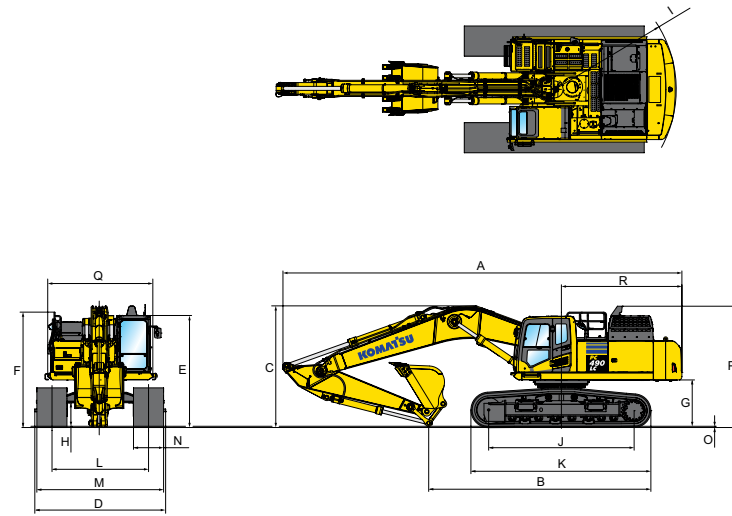

**Working range**

<b>Arm Length</b>	<b>3400 mm</b>	
A Max. digging height	10980 mm	
B Max. dumping height	7630 mm	
C Max. digging depth	7755 mm	
D Max. vertical wall digging depth	6805 mm	
E Max. digging depth for 8' level bottom	7615 mm	
F Max. digging reach	12030 mm	
G Max. digging reach at ground level	11810 mm	
H Min. swing radius	4735 mm	
SAE rating	Bucket digging force at power max.	239 kN 24,400 kg
	Arm crowd force at power max.	205 kN 20900 kg
ISO rating	Bucket digging force at power max.	275 kN 28000 kg
	Arm crowd force at power max.	214 kN 21800 kg

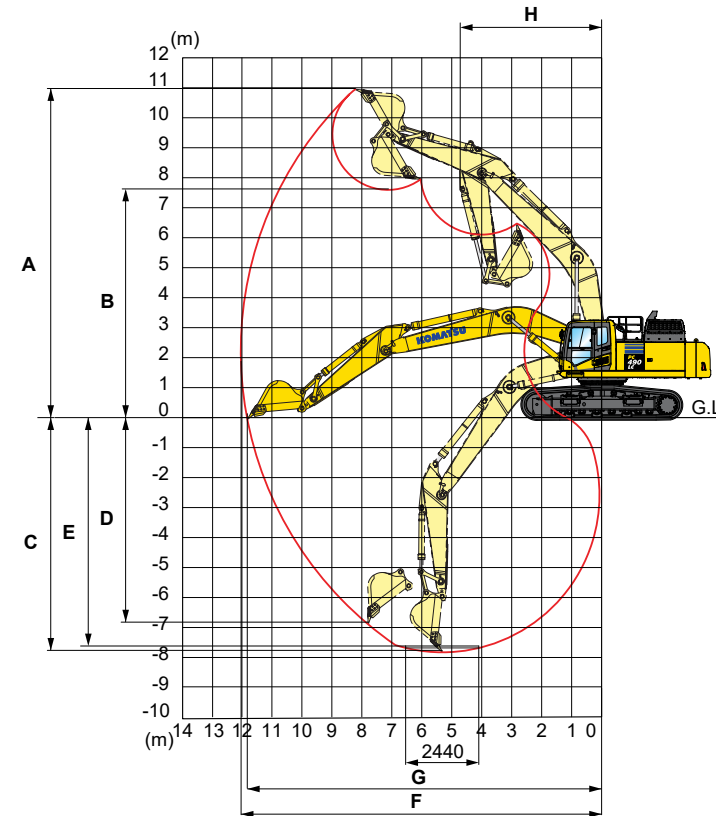

**Lift capacities**

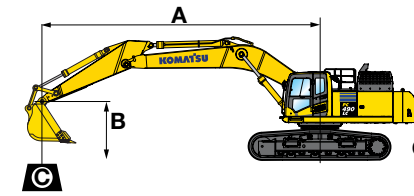

A: Reach from swing centre  
 B: Bucket hook height  
 C: Lifting capacity  
 Cf: Rating over front  
 Cs: Rating over side  
 ⊗: Rating at maximum reach

Conditions:  
 • Boom length: 7000 mm  
 • Arm length: 3400 mm  
 • Shoes: 600 mm triple grouser  
 • Bucket: 1914 kg

	A	3.0 m	4.5 m	6.0 m	7.5 m			Unit: kg	
B									⊗ MAX
7.5 m	-	-	-	-	-	-	-	-	*6350 *6350
6.0 m	-	-	-	-	-	*9700	*9700	*8950	7000 *6400 6000
4.5 m	-	-	-	-	*12590	*12590	*10700	9400	*9350 6800 *6600 5400
3.0 m	-	-	*21250	20000	*15200	12750	*11900	8950	*9950 6550 *7050 5050
1.5 m	-	-	*16000	*16000	*16850	12100	*12900	8550	*10500 6350 *7750 4950
0.0 m	-	-	*16450	*16450	*17500	11650	*13400	8250	10550 6150 8700 5050
-1.5 m	*9950	*9950	*22300	18250	*17250	11450	*13300	8100	10450 6050 9350 5400
-3.0 m	*20250	*20250	*21050	18450	*16150	11500	*12450	8100	*9450 6100 *9450 6150
-4.5 m	*22450	*22450	*17750	*17750	*13800	11700	*10350	8250	- - *9250 7700
-6.0 m	-	-	*12500	*12500	*9300	*9300	-	-	- - *8150 *8150

\*Load is limited by hydraulic capacity rather than tipping. Ratings are based on SAE standard No. J1097. Rated loads do not exceed 87% of hydraulic lift capacity or 75% of tipping load.





**Standard equipment**

- 3 speed travel with auto shift
- Access handrails – counterweight
- Alternator, 90 A, 24 V
- Arm, 3200 mm
- Auto idle
- Auto idle shut down
- Automatic air conditioner, large capacity
- Automatic engine warm-up system
- Auxiliary input (3.5 mm jack)
- Batteries, large capacity
- Battery isolation switch, lockable
- Boom, 6500 mm
- Boom and arm burst valve protection
- Bump rails
- Cab guards
  - Lower front window guard
  - Integrated top guard, OPG Level 1
  - Bolt on top guard, OPG Level 2
- Carrier rollers, (2 each side)
- Converter, (2) x 12 V
- Counterweight, 6920 kg
- Dry type air cleaner, double element
- Dual flow hammer piping
- Electric horn
- Emergency stops (3)
- EMMS monitoring system
- Engine, Komatsu SAA6D107E-3
- Fan guard structure
- Fire extinguisher, 1.5 kg (for PC360LCi-11)
- Fuel system pre-filter 10 micron
- Guard belly plate (for PC360LCi-11)
- High back air suspension seat, with heat
- High pressure in-line hydraulic filters
- Hydraulic track adjusters
- Hydraumind closed centre load sensing system
- Komtrax®
- Komvision (Standard on all models manufactured after August 2021)
- Large LCD colour monitor, high resolution
- Level indicator
- Lock lever
- Lock lever, auto-lock
- Mirrors (LH, RH & sidewise)
- Operator identification system (available August 2021)
- Overload alarm
- Power maximising system
- PPC hydraulic control system
- Proportional control handles
- Provision for tilt circuit, including valve
- Pump/engine room partition cover
- Quick hitch piping with safety switch and alarm
- Radiator and oil cooler dustproof net
- Radio Bluetooth USB media system
- Rear reflectors
- Revolving frame undercovers
- ROPS cab (ISO 12117-2) with vandal guard provisions
- Rearview monitoring system (1 camera) (For PC360LC-11 models manufactured before August 2021)
- Rotating beacon (LED) with guard
- Seat belt indicator
- Seat belt, retractable, 78 mm
- Secondary engine shutdown switch
- Side access hand rails
- Side by side coolers
- Slip resistant foot plates
- Starter motor, 11 kW/24 V x 1
- Suction fan
- Thermal and fan guards
- Track roller guides, 3 each side
- Track rollers, 8 each side
- Track frame swivel guard
- Track shoes, triple grouser, 600 mm
- Travel alarm
- Turbo timer
- Working lights
  - 1 x boom
  - 1 x RH
  - 3 x cab
  - 1 x counterweight
- Working mode selection system

**intelligent Machine Control**

- 12 month remote access to your machine (includes data & SIM)
- 12 months service level support agreement
- Auto grade assist
- Auto stop control boom and bucket
- Auto tilt attachment control [when tilt bucket fitted]
- Bucket angle hold
- Dual multi-constellation GNSS antennas
- Excavator weighing system
- Factory integrated 3D machine control
- iMC 2.0 canvas seat cover
- Komatsu chassis mounted iMU
- Komatsu PH700 monitor
- Komatsu stroke sensors [boom/arm & bucket]
- MC-i4 with internal 4G modem
- Minimum distance control
- Network and UHF antennas
- Receiver- UR-1 UHF and 915SS radio

**Optional equipment**

- Autogrease system
- Battery isolation switch, dual pole, lockable
- Belly plates, 8 mm
- Cab guard
  - Full front guard, OPG Level 2
- Cab vandal guard set
- Canvas seat cover
- Fire extinguisher, 1.5 kg
- Fire extinguisher, 4.5 kg
- Fire extinguisher, 9 kg
- Fuel cap vandal guard
- Jump start receptacle
- Radio 915SS
- Starter circuit isolation, lockable
- Track shoes, triple grouser, 700 mm
- Track shoes, triple grouser, 850 mm
- Window tinting

**Attachment options**

- Bucket, general purpose, KGA 650 mm, 0.53 m³
- Bucket, general purpose, KGA 1300 mm, 1.35 m³
- Bucket, general purpose, KGA 1500 mm, 1.61 m³
- Bucket, general purpose, KGA 1700 mm, 1.80 m³
- Bucket, rock, direct pin, KGA 1600 mm, 1.66 m³
- Bucket, slope finishing, KGA 2200 mm, 2.20 m³
- Quick hitch, KGA, dual lock
- Ripper, KGA, single tyne

# Notes

**Now available**

**Komatsu JMHB460H-1 Hydraulic Breaker**



Model Type	JMHB460H-1	
Working weight	kg	3,261
Oil flow (min - max)	ℓ /min	250 - 320
Operating pressure (max)	MPa	17.5
Impact rate	bpm	350-700
Chisel diameter	mm	175
Variable frequencies	-	2
Acceptable back pressure	bar	1.5
Base machine (min - max)	Ton	35 - 60

For a complete list of available attachments, please contact your local Komatsu representative.