



- Workshop Dome
- Sea Containers
- Site Offices
- Lunchrooms
- Accommodation Units
- Ablution Block

Portable Buildings

Brooks' portable container offices can be quickly deployed, from depot to site within days. They come fully equipped with all the features your team needs to stay safe and work efficiently. The containers are painted surf mist white for better temperature control inside the structure and come complete with split air conditioning for those hot and cold days.

All container office units are built with a strong focus on safety and security including internal and external lighting and windows with fly screens, security mesh and a heavy-duty steel personal access door with tri-locking system. The units are construction compliant with all Australian standards and the National Construction Code 2013 and can be supplied with cyclone kits.

Depending on your requirements, a range of internal layouts can also be designed with long-term hire durations.



Lunch Room

Lunch Rooms

FEATURES

20ft Container	40ft Container
<ul style="list-style-type: none"> ■ 2 x Foldable tables 	<ul style="list-style-type: none"> ■ 4 x Foldable tables
<ul style="list-style-type: none"> ■ 6 x Chairs 	<ul style="list-style-type: none"> ■ 24 x Chairs
<ul style="list-style-type: none"> ■ 1 x Kitchenette 	<ul style="list-style-type: none"> ■ 1 x Kitchenette
<ul style="list-style-type: none"> ■ 1 x Fridge 	<ul style="list-style-type: none"> ■ 1 x Fridge
<ul style="list-style-type: none"> ■ 1 x Microwave 	<ul style="list-style-type: none"> ■ 1 x Microwave
<ul style="list-style-type: none"> ■ 2 x 900x900mm sliding windows with security screen mesh 	<ul style="list-style-type: none"> ■ 3 x 900x900mm sliding windows with security screen mesh
<ul style="list-style-type: none"> ■ 1 x Heavy duty steel personal access door with tri-locking system and two keys 	<ul style="list-style-type: none"> ■ 1 x Heavy duty steel personal access door with tri-locking system and two keys
<ul style="list-style-type: none"> ■ 1 x 3.5kw split system air conditioner, recessed in the end wall 	<ul style="list-style-type: none"> ■ 1 x 5kw split system air conditioner, recessed in the end wall
<ul style="list-style-type: none"> ■ 2 x LED batten lights 	<ul style="list-style-type: none"> ■ 4 x LED batten lights
<ul style="list-style-type: none"> ■ 4 x Double 10amp GPO 	<ul style="list-style-type: none"> ■ 4 x Double 10amp GPO
<ul style="list-style-type: none"> ■ Recessed 15amp inlet or hardware junction box 	<ul style="list-style-type: none"> ■ Recessed 15amp inlet or hardware junction box

Site Offices

FEATURES

20ft Container	40ft Container
<ul style="list-style-type: none"> 3 x Desks 	<ul style="list-style-type: none"> 6 x Desks
<ul style="list-style-type: none"> 3 x Chairs 	<ul style="list-style-type: none"> 6 x Chairs
<ul style="list-style-type: none"> 2 x 900x900mm sliding windows with security screen mesh 	<ul style="list-style-type: none"> 3 x 900x900mm sliding windows with security screen mesh
<ul style="list-style-type: none"> 1 x Heavy duty steel personal access door with tri-locking system and two keys 	<ul style="list-style-type: none"> 1 x Heavy duty steel personal access door with tri-locking system and two keys
<ul style="list-style-type: none"> 1 x 3.5kw split system air conditioner, recessed in the end wall 	<ul style="list-style-type: none"> 1 x 5kw split system air conditioner, recessed in the end wall
<ul style="list-style-type: none"> 2 x LED batten lights 	<ul style="list-style-type: none"> 4 x LED batten lights
<ul style="list-style-type: none"> 4 x Double 10amp GPO 	<ul style="list-style-type: none"> 4 x Double 10amp GPO
<ul style="list-style-type: none"> Recessed 15amp inlet or hardware junction box 	<ul style="list-style-type: none"> Recessed 15amp inlet or hardware junction box

Accommodation Units

FEATURES

- 20ft GP New Build
- Internal room size: approx. 2850x2200mm
- Fully covered vinyl flooring
- Fully lined using 50mm EPS fridge panel

Each room includes:

- C/W Air Conditioning
- 1 x 945x945mm sliding window with grill
- 1 x tri-locking personal access door with two keys
- 1 x single bed
- 1 x light, light switch and a double 10amp GPO



Site Office

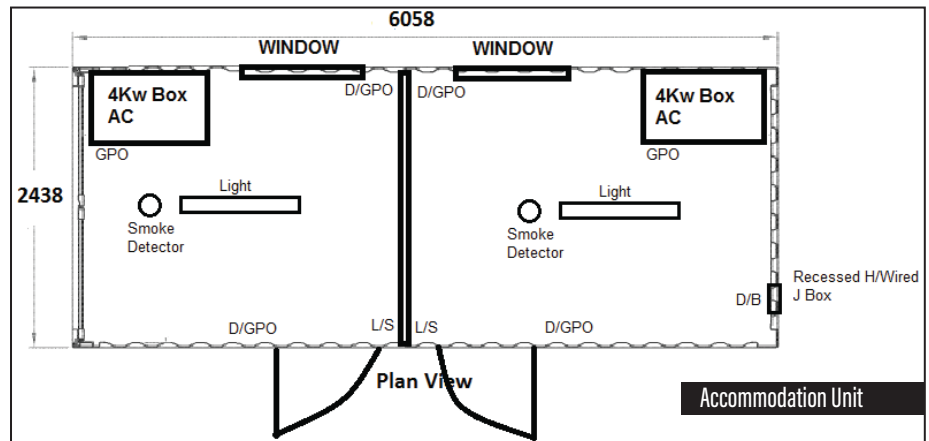

Ablution Block: 20ft Container

FEATURES

- M/F (4 Cubicles)
- Self-contained pump and waste tank
- 1 x High level float activated shutoff valve, designed to activate when waste tank is at 10% above high level alarm.
- Water will shut off and active only when tank is emptied.

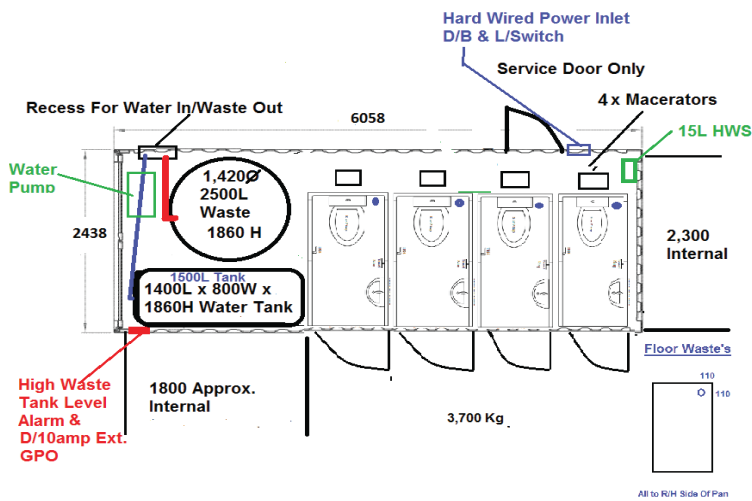

Delivery

Side Loader

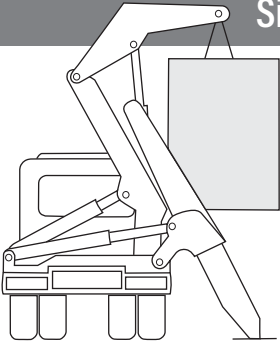

Side loaders are used to transport our 20 foot and 40 foot shipping containers. This is the best delivery method for containers at sites that have limited space either in front or behind the area where the container is to be positioned. The container is unloaded between the two outrigger feet of the side loader, approximately held a metre from the side of the truck.

Tilt Tray

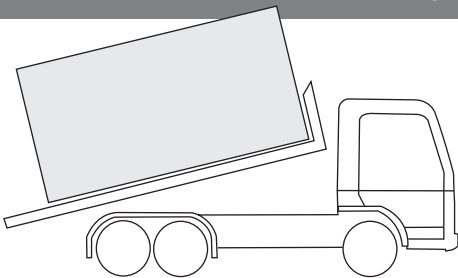

Tilt tray delivers a container off the back of the truck. Similar to a tow truck, the tray is mechanically lowered at an angle, and the container is slid off, with the truck moving forward at slow speed. This is the most common delivery method used for containers. Tilt trays are not suitable for sites with overhead power lines as the container height increases significantly when tilted.

Hiab Crane

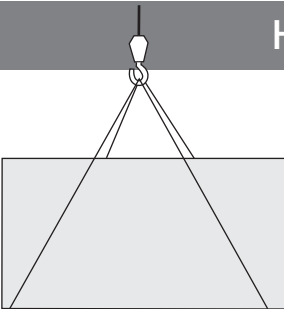

Hiab cranes lift containers from a mechanism located behind the truck's cabin. This is used when there is limited space for a side loader or tilt tray. Using a crane means the container is easily positioned at an angle or up on a raised area. It can also be used to place containers over a fence or other obstacles.



CONTACT OUR SITE SERVICES TEAM



David Welch
General Manager

☎ 0499 940 449
@ dwelch@brookssiteservices.com.au



Troy Turner
Fleet Services Manager

☎ 0477 999 447
@ tturner@brooksfleet.com.au



Blair Chamberlain
Senior Hire Coordinator

☎ 0428 840 814
@ bchamberlain@brookssiteservices.com.au



Lil Ahmad Daud
Hire Coordinator

☎ 0447 254 974
@ lahmaddaud@brookshire.com.au

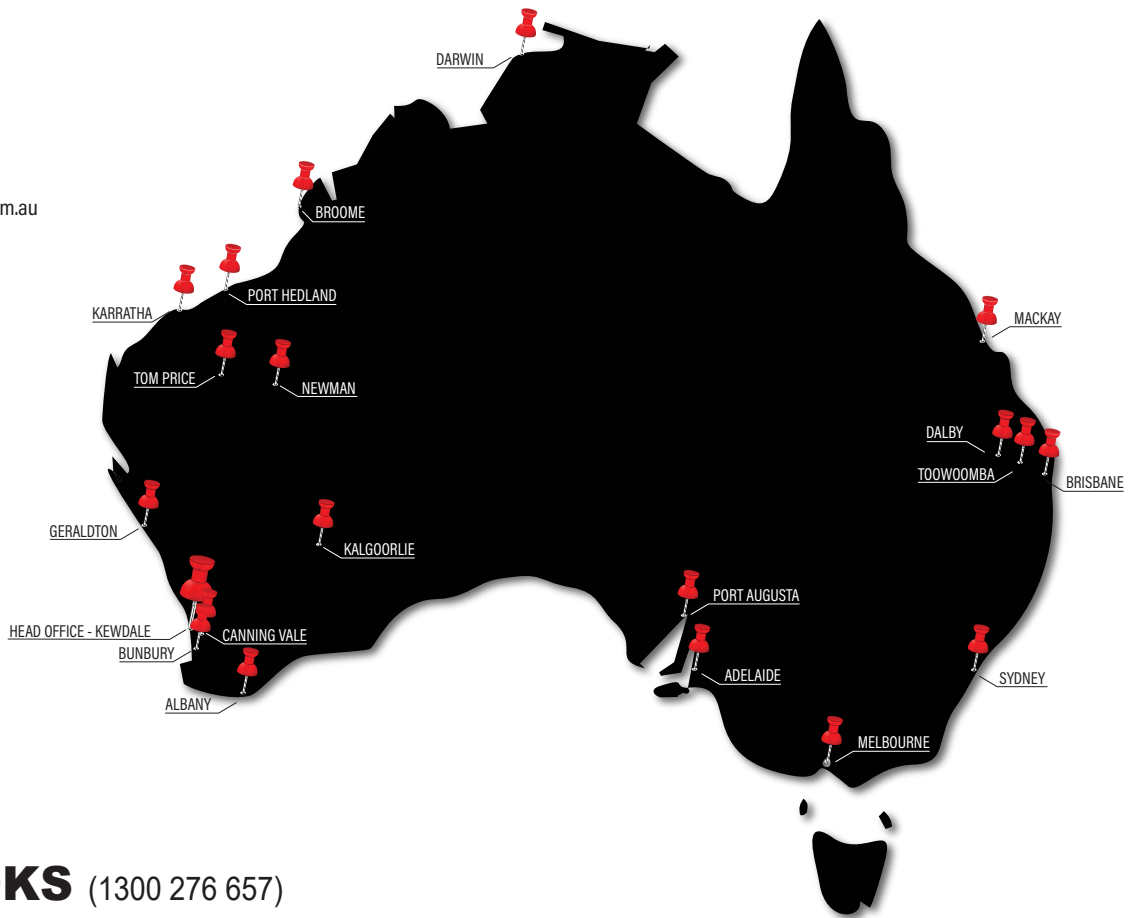

☎ **1300 BROOKS** (1300 276 657)
@ sales@brookssiteservices.com.au
🌐 **www.brookshire.com.au**

BROOKS
SITE SERVICES



“Better Being With Brooks”